

JVC

NAVIGATIONSSYSTEM/CD-RECEIVER
NAVIGATION/CD RECEIVER
AUTORADIO CD/SYSTEME DE NAVIGATION
SINTOAMPLIFICATORE CON RIPRODUTTORE DI NAVIGATION/CD

KD-NX1R



COMPACT
disc
DIGITAL AUDIO

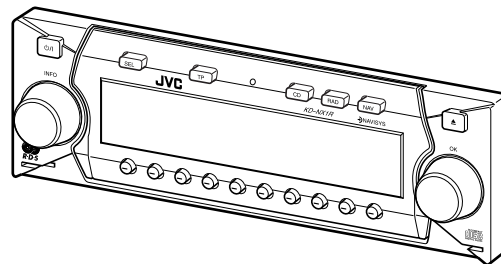

BEDIENUNGSANLEITUNG
INSTRUCTIONS
MANUEL D'INSTRUCTIONS
ISTRUZIONI

Wir möchten Ihnen danken, daß Sie sich für eines unserer JVC-Produkte entschieden haben.

Ehe Sie diese Anlage an die Stromversorgung anschließen, lesen Sie bitte diese Bedienungsanleitung sorgfältig und gründlich durch, um so eine optimale Anlagenleistung zu erzielen, und heben Sie diese Bedienungsanleitung auf, damit Sie in Zukunft darin nachlesen können.

We would like to thank you for purchasing one of our JVC products.
Before operating this unit, read this manual carefully and thoroughly to obtain the best possible performance from your unit, and retain this manual for future reference.

Nous vous remercions d'avoir acheté un de nos produits JVC.
Avant d'utiliser cet appareil, lisez attentivement ce mode d'emploi afin d'obtenir les meilleures performances de l'appareil, et conservez-le à titre d'information.

Nel ringraziarLa per aver scelto un prodotto JVC, ci auguriamo che possa essere pienamente soddisfatto della Sua scelta.
Ai fini dell'ottenimento delle migliori prestazioni, La invitiamo a leggere con attenzione il presente manuale d'istruzioni prima di collegare ed accendere l'impianto.

Bedienungsanleitung

DEUTSCH

Instructions

ENGLISH

Manuel d'instructions

FRANÇAIS

Istruzioni

ITALIANO



Important! Safety instructions

Use of the navigation unit is only permitted if the traffic conditions are suitable and you are absolutely sure that no risk, obstruction or inconvenience will be incurred to you, your passengers or other road users.

The requirements of the Road Traffic Regulations apply at all times. The destination must only be entered when the vehicle is stationary.

The navigation system serves solely as an aid to navigation. It neither releases the driver from his duty to drive carefully in road traffic, nor does it take the place of his own ability to make judgement. It is possible that inaccurate or incorrect instructions are given due to changing traffic conditions or varying data. The actual road signs and traffic regulations must therefore always be observed. In particular, the navigation system cannot be used as an aid to orientation when visibility is poor.

The unit must only be used for its intended purpose. The volume of the car radio/navigation system must be adjusted so that external noise is still audible.

Switch off the unit immediately if a fault occurs (e.g. emission of smoke or odours).

In the interest of safety, the unit must only be opened by a specialist. Please refer to your dealer for repair.

Contents	73	Route guidance calculation	91
Arrangement of controls	75	Stopover	92
Anti-theft system	76	Traffic jam function	93
Entering the code number	76	Cancelling route guidance	94
Removing the portable panel	77	Notes on route guidance	95
Inserting portable panel	77	Dynamic navigation with TMC	97
General operation	78	Information during route guidance	100
Switch on/off	78	Destination memory	103
Adjusting the volume	78	Special destinations	103
Activating the tone menu	78	System settings	106
Setting the bass	78	Radio operation	112
Setting the treble	78	Switching on radio mode	112
Setting the fader	79	Switching on radio menu mode	112
Setting the balance	79	Selecting the FM waveband	112
Linear setting	79	Selecting the AM waveband	112
Setting the subwoofer or centre speaker volume	79	Setting options for transmitter selection	112
Switching loudness on/off	79	Dynamic autostore (FM DAS)	113
Navigation operation	80	FM DAS transmitter search	113
What is navigation?	80	Transmitter search MW, LW, SW	113
Safety instructions	80	Scan search	114
Digitised area	80	Programme filtering for FM DAS	114
General notes	81	Programme type selection (PTY)	114
Selecting navigation	82	Switching PTY display on/off	115
Main navigation menu	82	Requesting/storing FM transmitters	115
Entering destination	83	Requesting/storing MW, LW, SW transmitters	115
Route menu	88	MW, LW autostore	116
Storing a specified destination in the destination memory	90	FM manual tuning	116
		MW, LW, SW manual tuning	116
		Regionalisation	117

Contents

Switching regionalisation on/off	117	Intro scan	127
Switching frequency display on/off	117	Fast forward/rewind	128
Switching radio text display on/off	118	Random play	128
Traffic Programme (TP)	118	Repeating a track	128
Activating/quitting the TP menu	119	Number of tracks and total playing time	128
Switching TP on/off	119	PSM (Preferred Setting Mode) menu	129
Selecting automatic tracking	120	Requesting/quitting PSM menu	129
Selecting/deleting direct programming	120	GAL (Gal) setting	130
Switching mute on/off	120	Telephone mute characteristics (Tel)	130
Interrupting TP announcements	121	(Col) display colour setting	131
TP announcement volume	121	Display setting (Lcd)	131
Switching TMC on/off	121	LED setting	132
Display for TMC stations	122	Setting reception optimisation (M/S)	132
Telephone mute function	122	Setting navigation announcements (Nav)	133
CD operation	123	AUX input (Aux)	133
Compact Disc (CD) instructions	123	Compass display	134
Inserting/ejecting CDs	123	Signal tone volume	134
Track skip - forwards/backwards	124	Connection instructions	135
Intro scan	124	Removal/installation instructions	136
Fast forward/rewind	124	General instructions	138
Random play	124	RDS SYSTEM	138
Repeating a track	125	DAS Seek Qual. plane	138
Number of tracks and total playing time	125	DAS Seek Name plane	138
Temperature protection circuit	125	Stations Fix plane	138
CD changer operation	126	Stations RDS plane	138
Operational readiness of CD changer	126	PTY (Programme Type)	139
CD magazine - load/unload	126	Technical data	140
Playing CDs	127		
Track skip - forwards/backwards	127		

Arrangement of controls

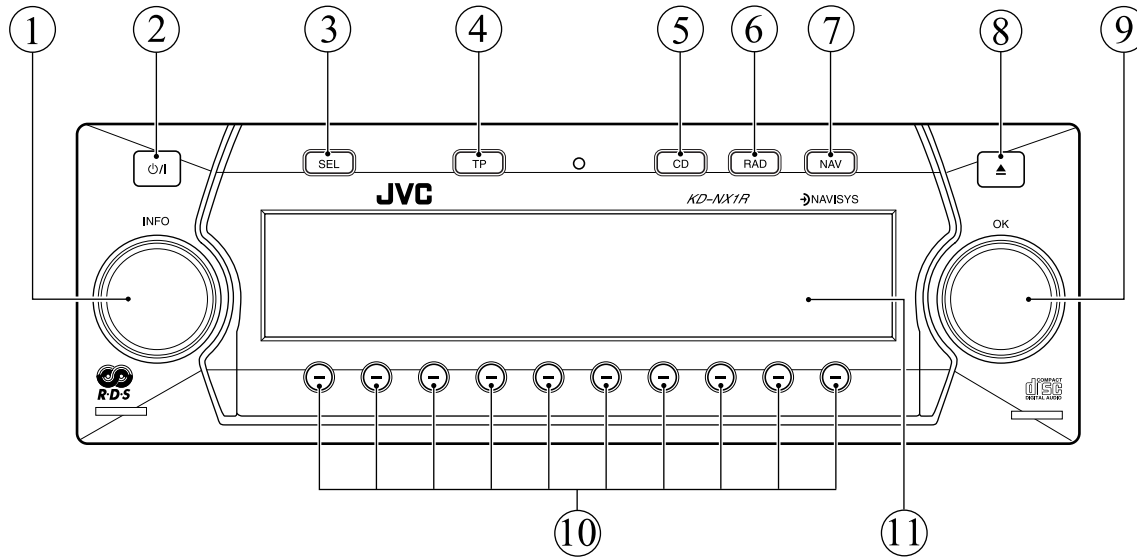

- | | |
|--|---|
| ① Left rotary control ● (Info) | ⑦ Select navigation mode (NAV) |
| ② On/off switch (O/I) | ⑧ CD eject button (▲) |
| ③ Tone button (SEL) | ⑨ Right rotary control ● (Ok) |
| ④ Traffic programme button (TP) | ⑩ Multifunction buttons |
| ⑤ Select CD mode (CD) | ⑪ Display |
| ⑥ Select radio mode (RAD) | |

Anti-theft system

Entering the code number

If the car radio is disconnected from the power supply, it is theft-protected upon reconnection. After switching on via the  button, the prompt Enter Code Number, is displayed.

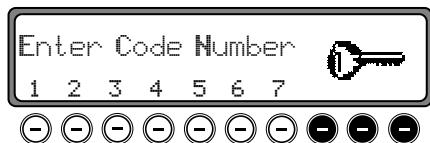

The five-digit code must then be entered using the multifunction buttons "1 - 7".

Example: Code number 15372 (the code number can be found on the enclosed CODE CARD).

Enter code number using the multifunction buttons.
The unit automatically switches when the fifth digit is entered and all other digits have been entered correctly.

Note: It is essential that the CODE CARD be kept in a safe place outside the vehicle. Thus, illegal use is not possible. The sticker provided should be attached to the inside of the vehicle windscreen/window.

If an incorrect code number is entered, the prompt Enter Code Number is displayed again. After entering an incorrect code three times Code wait is displayed and the unit is disabled for approx. 60 minutes.

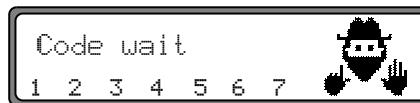

Three further incorrect entries block the unit for another 60 minutes.

Attention: The disabling period functions only with the unit switched on.

Removing the portable panel

As an effective anti-theft device, the portable panel (A) can be removed from the unit.

Press  button briefly (storage medium remains in the unit). The display folds forwards. The portable panel can then be pulled out.

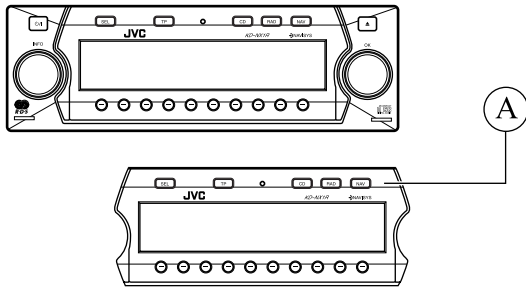

The volume is limited to a maximum value after the display has been folded down. After 20 seconds an audible signal indicates that the control component is folded down. The unit then switches off automatically.

Note: For safety reasons, it is not permitted to leave the portable panel open when driving.

Attention: Please insert the portable panel in the accompanying protective cover after removal. Do not touch the metal contacts on the portable panel or on the radio.

Inserting portable panel

Insert the portable panel in the lower left catch and then engage it in the lower right catch. Then fold up the portable panel and engage it in the upper catches.

Alternately, position portable panel directly over all four catches and press in firmly to engage.

For correct functioning, ensure that the portable panel is firmly engaged in all four catches.

If a new portable panel or one from another unit is utilised, the code number must be entered, as previously described, in order to activate the unit.

General operation

Switch on/off

Press  button.

Additional options for switching on/off: via ignition. In order to switch on via the ignition, the unit must have been switched off previously via the ignition. After switching off the ignition, the unit can be prevented from switching off by pressing the  button within 3 seconds.

Note: With the ignition switched off, the unit can also be switched on via the  button. The unit switches off automatically after 1 hour.

Adjusting the volume

Turn the left rotary control . The volume is increased or decreased.

Activating the tone menu

Press  button. The tone menu is activated. The following functions can be requested: **Bas** (Bass), **Trb** (Treble), **Fad** (Fader), **Bal** (Balance), **Flt** (Linear setting), **Sub** (Subwoofer) and **Ldn** (Loudness).

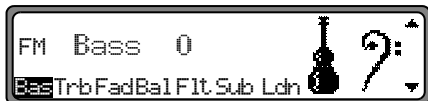

Settings for the bass and treble are stored separately for wavebands MW/LW/SW and FM, for traffic announcements, navigation messages, telephone operation, CD and CDC/AUX operation.

Setting the bass

Press the  button and then the multifunction button **Bas**.



Set the desired bass level using the right rotary control .

Setting the treble

Press the  button and then the multifunction button **Trb**.



Set the desired treble level using the right rotary control .

Setting the fader

Press the **SEL** button and then the multifunction button **Fad**.



Use the right rotary control for the desired fader setting.

Setting the balance

Press the **SEL** button and then the multifunction button **Bal**.



Set the desired balance level using the right rotary control.

Linear setting

Briefly press the **SEL** button.

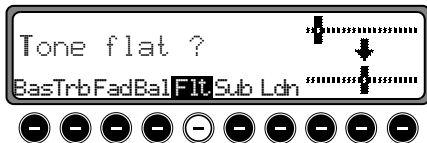

Press the multifunction button **Fit** - Tone flat is displayed. By pressing the multifunction button **Fit** again the tone settings for the currently selected signal source (e.g. FM) are set to an average value.

Setting the subwoofer or centre speaker volume

Press the multifunction button **Sub**.



Use the right rotary control to set the desired subwoofer volume level.

Switching loudness on/off

Press the **SEL** button and then the multifunction button **Ldn**.



Using the multifunction button **Ldn** you can select either loudness on (ON) or loudness off (OFF).

Loudness is switched off in MW, LW and SW wavebands.

Navigation operation

What is navigation?

The term “navigation” (lat. navigare = to travel by sea) is generally understood to mean the location of a vehicle, the determination of the direction and distance from the desired destination and the required route. Stars, prominent landmarks, compasses and satellites etc. are used as navigation tools.

With the KD-NX1R, the location is determined via the GPS receiver (GPS = Global Positioning System). The direction and distance from the destination is determined using a digital street map, a navigation computer and sensors. A speedometer and reverse signal are additionally used to calculate the route.

For safety reasons, route guidance follows predominantly in spoken form supported by a direction indicator on the display.

Safety instructions

- The requirements of the Road Traffic Regulations (RTR) apply.
- Observation of traffic signs and local traffic regulations always takes priority.
- Traffic guidance is restricted to passenger vehicles. Special driving recommendations and regulations for other vehicles (e.g. commercial vehicles) are not taken into account.
- The destination must only be entered when the vehicle is stationary.

Digitised area

The navigation CD provided contains a digitised street map. Motorways, federal and regional roads, as well as district roads are detailed in this street map. Larger cities and boroughs are completely covered. The regional and unclassified roads or access roads and the town centre for smaller towns and boroughs are included.

One way streets, pedestrian zones, turn bans and other traffic regulations are taken into account as far as possible. There may be discrepancies between the data on the navigation CD and the actual local situation, due to permanent changes to road systems and their traffic regulations.

General notes

- Radio or CD operation continues during navigation operation.
The distance to be covered before the next announcement and the estimated time of arrival are always displayed at the right of the display.
- The unit can be switched to radio mode when route guidance is in operation by pressing the **RAD** button. Press the **CD** button to switch to CD mode.
The navigation menu is automatically displayed when navigation announcements are given.
- When entering the address, only those letters, digits and symbols which are relevant for the address are displayed. The entries are automatically completed.
Spaces (e.g. in Bad Abbach) must be entered using the underline symbol.
Letters, numbers and symbols can be selected via the multifunction buttons **1** to **9**. The individual symbols can be selected by pressing the relevant multifunction buttons repeatedly.
Selection can also be made using the right rotary control **➤**, as described later in this guide.
- **NAV** quits the current menu and displays the previous menu.
- The route is recalculated by the system if deviation from the route is made.
- Press the left rotary control **⦿** to hear the current navigation announcement.
- During the navigation announcement, adjustment can be made to the volume using the left rotary control **⦿** and to the tone by pressing the **BEL** button (see page 78).
- By briefly pressing the left rotary control **⦿** additional information can be requested during route guidance or the current position when route guidance is not active. See “Information during route guidance” on page 100.
- The current navigation announcement is interrupted by pressing the left rotary control **⦿**.
- If the left rotary control **⦿** is pressed for longer than 2 seconds during a navigation announcement, the navigation announcement switches off and route guidance continues via display only.
By briefly pressing the left rotary control **⦿** the navigation announcements are switched on again.
- The scroll marks **▲** and **▼** indicate a selection list which can be scrolled through using the right rotary control **➤**. Each entry in the list shown in capital letters can be selected by pressing the right rotary control **➤**.



Navigation operation

Selecting navigation

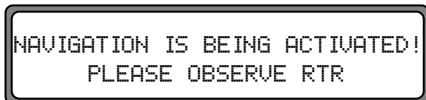
Press  button.



The main navigation menu appears after this display.

- Note:** The navigation CD must be loaded when starting navigation operation for the first time. If the navigation system has not yet been calibrated, a calibration journey is prompted (see Installation/Connection Manual). A navigation CD with the data for the destination country is required for navigation operation. The navigation CD must be inserted to start the route calculation. During the calculation, the prompt  flashes on the display. Once the calculation has been completed, the prompt  extinguishes, the navigation CD can be removed and an audio CD can be inserted. When entering destinations, driving off should be delayed until the prompt  disappears.

Main navigation menu





Selection from

DESTINATION,
DEST. MEMORY,
P.O.I.,
LAST DESTINATIONS,

can be made by turning the right rotary control, and confirmed by pressing the right rotary control .

- DESTINATION
accesses the entry menu for the destination. See “Entering destination” on page 83.
- DEST. MEMORY
contains destinations which have been stored previously. See “Destination memory” on page 103.
- P.O.I
Menu for the selection of special local and interregional destinations and special destinations nearby. Special destinations are e.g. petrol stations, airports or hospitals. See “Special destinations” on page 103.

- **LAST DESTINATIONS**

A list of the last 50 destinations is displayed. The desired destination can be selected using the right rotary control . Before confirming with the right rotary control , details of the destination can be requested by pressing the left rotary control . Stopovers are not stored as last destinations.

Entering destination

Select **DESTINATION** in the main navigation menu using the right rotary control  and press to confirm.

Selecting the country



If your destination lies in another country, select **GERMANY** using the right rotary control  and press to confirm.



Select the country using the right rotary control  and press to confirm.

Note: We recommend the selection of a stopover (see page 92) at the half-way point to the destination.

Navigation operation

Entering the destination



The last location entered is displayed. If you want to enter a destination in the displayed location, you can select ROAD or CENTRE immediately. If your destination lies in another location, select the location using the right rotary control **⦿** and press to confirm.



Select the letters one after the other by turning the right rotary control **⦿** and press to confirm. The enlarged selected letter appears at the right of the display.

Using the multifunction button **⌘** the last confirmed letter is deleted.

The complete entry is deleted if the multifunction button **⌘** is pressed for more than 2 seconds.

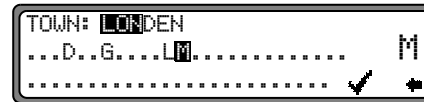

Letters which are already entered are displayed inversely. For the purpose of support, the existing entry is displayed at the next place-name to be reached. The unit offers only the possible remaining letters for selection. If no other entries are available, the unit completes the place-name automatically.

To accept the entry, press and hold the right rotary control **⦿** for more than 2 seconds or select the small tick **✓** and briefly press the right rotary control **⦿**.

If the complete place-name was previously entered or was automatically completed, the program switches to either place-distinguishing list or to road or centre entry.

If no roads and only the centre can be selected in the location entered, the program switches directly to route menu.

If an incomplete location entry was confirmed, the place selection list is displayed.



The place nearest to the entry appears in capital letters in the place selection list.

The scroll marks indicate that more places are available for selection in alphabetical order.

Select by turning and confirm by pressing the right rotary control . (See “General notes” on page 81.)

If the entry is unequivocal, the program switches to road or centre entry. If no roads and only the centre can be selected in the location entered, the program switches directly to route menu.

The place-distinguishing list is displayed if the selection is ambiguous.

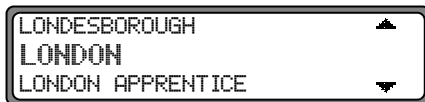

Select the required place using the right rotary control  and press to confirm.

The program switches to road or centre entry.

If no roads and only the centre can be selected in the location entered, the program switches directly to route menu.

Entering the destination road



Using the right rotary control , select ROAD and press to confirm.



Select the letters one after the other by turning the right rotary control  and press to confirm. The enlarged selected letter appears at the right of the display.

Using the multifunction button  the last confirmed letter is deleted.



The complete entry is deleted if the multifunction button  is pressed for more than 2 seconds.



Letters which are already entered are displayed inversely. For the purpose of support, the existing entry is displayed at the next road to be reached. The unit offers only the possible remaining letters for selection.

Navigation operation

If no other entries are available, the unit completes the road-name.

To accept the entry, press and hold the right rotary control  for more than 2 seconds or select the small tick  and briefly press the right rotary control .

If the complete road-name was previously entered or was automatically completed, the program switches to either road-distinguishing list or to route menu.

If an incomplete location entry was confirmed, the road selection list is displayed.



The road nearest to the entry appears in capital letters in the road selection list.

The scroll marks indicate that more roads are available for selection in alphabetical order.

Select the road by turning the right rotary control  and press to confirm.

If the entry is unequivocal, the program switches to route menu.

The road-distinguishing list is displayed if the selection is ambiguous.



Select the required place using the right rotary control  and press to confirm.

The program switches to route menu.

Entering the destination centre



Using the right rotary control , select CENTRE and press to confirm.

If the place selected only has one centre, the program switches immediately to route menu.

If the number of centres is less than 10, the centre list is displayed.



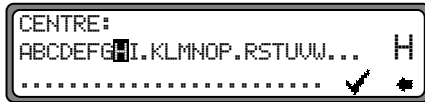

Select the centre by turning the right rotary control  and press to confirm.

If the number of centres is greater than 9, the program switches to centre entry.





Select the letters one after the other by turning the right rotary control  and press to confirm. The enlarged selected letter appears at the right of the display.

Using the multifunction button  the last confirmed letter is deleted.

The complete entry is deleted if the multifunction button  is pressed for more than 2 seconds.



Letters which are already entered are displayed inversely. For the purpose of support, the existing entry is displayed at the next centre to be reached. The unit offers only the possible remaining letters for selection. If no other entries are available, the unit completes the centre-name.

To accept the entry, press and hold the right rotary control  for more than 2 seconds or select the small tick  and briefly press the right rotary control .

If the complete centre-name was previously entered or was automatically completed, the program switches to route menu.

The program switches to the centre list if the selection is ambiguous.



The centre nearest to the entry appears in capital letters in the centre list.

The scroll mark indicates that more centres are available for selection in alphabetical order.

Select the centre by turning the right rotary control  and press to confirm.

The program switches to the route menu.

Note: A list of possible centres is displayed immediately by pressing the right rotary control  for more than 2 seconds without having selected any letters.

Navigation operation

Route menu



Selection from

SAVE DESTINATION,
START-FAST R., (START-SHORT R. or
START-DYN. R.)
HOUSE NUMBER,
CROSSING
ROUTE SETTING

can be made by turning, and confirmed by pressing the right rotary control .



- **SAVE DESTINATION**
Accesses the entry menu for the destination memory (see page 90).
- **START-FAST R., START-SHORT R. or START-DYN. R.**
Starts route guidance. Simultaneously, a prompt appears indicating the currently selected route option (-SHORT R. for a short route, -FAST R. for a fast route and -DYN. R. for a dynamic route).
- **HOUSE NUMBER**
The house number in the specified destination road can be entered here.
This function is only available if this information is stored on the navigation CD.

- **CROSSING**
An intersecting road can be defined as the destination here.
This function is only available if this information is stored on the navigation CD.
- **ROUTE SETTINGS**
Specifications such as quick route, short route, dynamic route, motorway, ferries and toll roads can be selected here.

Entering the house number for the destination road

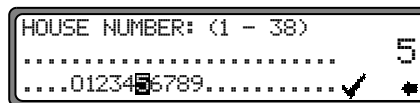
Using the right rotary control  select **HOUSE NUMBER** in the route menu and press to confirm.



Using the right rotary control , enter the house number for the destination road and press for more than 2 seconds to confirm the entry. To confirm, the small tick  can also be selected and the right rotary control  briefly pressed.
Due to the system characteristics, route guidance continues only in the area of the house number specified.



Select **START-** to start route guidance.

Select **SAVE DESTINATION** to jump to the destination memory menu.

Select **ROUTE SETTINGS** to access the possible route settings.

Select by turning the right rotary control  and press to confirm the selection.

Select the intersection for the destination road

Using the right rotary control , select **CROSSING** in the route menu and press to confirm.



Select the intersection for the destination road by turning the right rotary control  and press to confirm.



Select **START-** to start route guidance.

Select **SAVE DESTINATION** to jump to the destination memory menu.

Select **ROUTE SETTINGS** to access the possible route settings.

Select by turning the right rotary control  and press to confirm the selection.

Selecting the route settings

Using the right rotary control , select **ROUTE SETTINGS** in the route menu and press to confirm.



- **FAST ROUTE**
If selected, the program calculates the shortest possible journey time.
- **SHORT ROUTE**
If selected, the program calculates the shortest possible distance.

Note: The setting “SHORT ROUTE” is often recommended for larger cities or conurbations.

- **DYNAMIC ROUTE**
Dynamic route guidance is used to calculate the route, taking current traffic announcements into account.

Note: Can only be selected if TMC has been switched on or is currently switched on. See “Switching TMC on/off” on page 121.

If dynamic route guidance has been activated, the routes are calculated using the “FAST ROUTE” setting.

Navigation operation

See “Dynamic navigation with TMC” on page 97 for further information.

- **RESTRICTIONS**

Provides options for avoiding motorways, ferries or toll roads.



Selection can be made by turning the right rotary control, and settings can be changed by pressing the right rotary control ●.

Press the control for more than 2 seconds to accept all settings and quit the menu.

Note: Routes without motorways can only be calculated for short distances (up to 200 km).

Storing a specified destination in the destination memory

It is not absolutely necessary to store a destination in the destination memory for route guidance. It saves repeated manual entry, if the destination is required at a later date.

Select **SAVE DESTINATION** in the route menu and press the right rotary control ● to confirm.



Any name of your choice consisting of up to 20 characters can be entered for the specified destination and then automatically stored in the destination memory after pressing the right rotary control ● for more than 2 seconds. See “Destination memory” on page 103.

To store, the small tick ✓ can also be selected and the right rotary control ● briefly pressed.

If you do not wish to enter a name of your choice, press and hold the right rotary control ● for more than 2 seconds to store the address as previously entered in the destination memory.

The last destination entered can be filed at any position by turning the right rotary control ●. The memory position is confirmed by briefly pressing the right rotary control ●.

A total of 50 destinations can be stored.



For final storage in the destination memory, either route guidance must be started or the program must be switched to new destination entry by selection of **NEW DESTINATION**.

Deleting stored destinations

Select destination memory (see page 103).



Select the destination to be deleted using the right rotary control and press the **DEL** multifunction button.

Destination memory full



Occurs when the destination memory is full. Select either **DELETE** (to jump to the destination memory in order to delete a destination) or **BACK** (to cancel saving).

Route guidance calculation



The message “Calculating route” indicates that the distance is being calculated, which may take several seconds. After the first route guidance announcement, the prompt **CD** flashes on the display until the route has been completely calculated. When entering a destination, driving off should be delayed until **CD** no longer flashes.

Recalculating the route.



If the current route is not followed due to road blocks, diversions, unintentional driving in the wrong direction or failing to observe the recommendations, the system immediately calculates a new route. During this recalculation, **NEW ROUTE** is displayed.

Navigation operation

Stopover

This function enables a stopover to be entered when route guidance is active.

Entering a stopover



Press the multifunction button .



Using the right rotary control , make a selection and press to confirm.

- DEST. MEMORY
(see page 103) Select the stopover from the destination memory.

- DESTINATION
(see page 83) Allows entry of a stopover with the precise specification of the address.
- P.O.I
(see page 103) Enables the selection of special destinations as stopovers via LOCAL AREA, NEAR DESTINATION and TOWN/COUNTRY, e.g. petrol stations or airports.
- LAST DESTINATIONS
(see page 83) Allows entry of the stopover from the last destinations.

Starting route guidance to a stopover



To start route guidance to the stopover, press the right rotary control .
The route is calculated and route guidance begins.

Note: The  symbol is displayed inversely during route guidance to a stopover.

Deleting a stopover

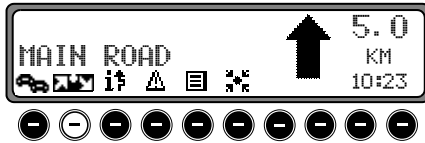

Press the multifunction button .



To delete the stopover, press the right rotary control  within 8 seconds.

Stopover reached



Route guidance to the final destination automatically starts following the message YOU HAVE REACHED YOUR STOPOVER.

Traffic jam function

This function allows you to block the approaching route sections as from the next junction and calculate a bypass route when a traffic jam or road block is directly ahead.

Entering the length of the traffic jam



Press the multifunction button .



Using the right rotary control , select the length of the traffic jam and press to confirm.



 is displayed inversely and the route is recalculated.

Navigation operation

Delete block



Press the multifunction button .



To delete a block, press the right rotary control  within 8 seconds.

Cancelling route guidance

Press  button.

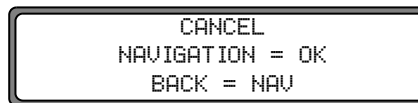

Route guidance is cancelled by pressing the right rotary control  within 8 seconds.

Otherwise, route guidance continues.

Notes on route guidance

After entering the destination (address), the system calculates the route and announces:
“Ready to drive off”.

The driving recommendations are given by voice messages and displays on the screen.

By pressing the left rotary control  the current driving recommendation can be repeated.

If the route to be travelled is not clear, e.g. at an intersection where a change in direction is not specified, the direction of travel can be displayed by pressing the right rotary control .



Please follow the direction indicated by the arrow.

The display appears for 8 seconds after pressing the right rotary control .



Danger!

If a driving recommendation contradicts the applicable Road Traffic Regulations (RTR), the RTR is always valid!

For clarification, there follows a selection of examples of possible driving recommendations:

- “Please perform a U-turn if possible”.



You are driving in the wrong direction and should turn back at the earliest opportunity.

- “Please turn right after 300 metres”.



The arrow indicator  points to the next street into which you should turn.

The progress bar on the right illustrates the distance and the black part decreases as you approach the intersection.

Navigation operation

- “Please follow the road”.



This display tells you that you should follow the course of the road.

- “Prepare to turn left” or
“Please move into the left-hand lane”.



This recommendation prepares you for the next turning to be taken.

However, “move into the left-hand lane” does not mean that you should do so immediately!

Note: At junctions and roundabouts, only the end of the road which is to be passed is displayed.

- “Please leave the roundabout at the third exit on the right”.



This display shows you which exit (marked with the arrow) you must take at the roundabout.

- “Now drive straight ahead”.



At this point, you must drive straight ahead.

- “Please follow the direction arrows”.



This display tells you that you are in a non-digitised street (e.g. car park, garage), which is not included in the digital street map. The arrow indicates the direction of the destination as the crow flies.

- “Keep right after 2 kilometres”.



Keeping to the right means that the road forks and you should follow the relevant direction.

- “You have reached your destination”.



The destination specified is reached and route guidance is terminated.

Dynamic navigation with TMC

Note: Dynamic route guidance is not possible in all countries.

To use dynamic navigation and the functions described below, TMC must be switched on, as described under “Switching TMC on/off” on page 121.

When any route recalculations are made with active dynamic route guidance, the navigation system may request the Navigation CD (if the Navigation CD is not already inserted).

What is dynamic route guidance?

Dynamic route guidance is used to calculate the route, taking current traffic announcements into account.

The traffic announcements are transmitted by a TMC radio station in addition to the radio programme and are received and analysed by the navigation system. There is no charge for receiving traffic announcements.

Note: Traffic announcements are transmitted by radio stations, therefore we cannot accept any responsibility for the completeness and correctness of the announcements.

Navigation operation

Dynamic route guidance

Dynamic route guidance can be started by selecting **START-DYN. R.** in the route menu.

If dynamic route guidance has been activated, a continuous check is made for the presence of relevant announcements for the selected route. The route is then calculated using the “**FAST ROUTE**” option, while taking into account current traffic announcements. If the check determines that a traffic announcement is relevant for the route guidance, then a new route to the destination is calculated automatically by the unit. **NEW ROUTE** appears on the display. In addition, there is a voice announcement “**The route is being recalculated due to current traffic announcements**”. **i** is displayed inversely.

Note: If no TMC station is found, then **FOR THE TIME BEING TMC RECEPTION IS NOT POSSIBLE** is displayed. After a short time, the unit switches back to the route guidance display. If a TMC station still cannot be found after 10 minutes, **FOR THE TIME BEING TMC RECEPTION IS NOT POSSIBLE** is displayed, accompanied by a brief signal tone.

Your navigation system can receive TMC information, whether a TMC station is selected or not. However, in order to guarantee optimal reception of TMC information, we recommend the selection of a TMC station. During radio operation (FM), a selected TMC station can be recognised by the abbreviation **TMC**. See “Display for TMC stations” on page 122.

Displaying traffic information

Current traffic announcements can be displayed in plain text. There are several options for requesting current traffic information.

Traffic information can be requested via the multifunction buttons **i** and **A** in the route guidance display and, in the case of inactive route guidance, via the multifunction button **A** in the information menu.

Route guidance display:



A list of all current traffic information which is relevant for the calculated route is displayed by pressing the multifunction button **i**.

A list of all currently available traffic information is displayed by pressing the multifunction button **A**.

Note: If no traffic information is currently available, **NO TRAFFIC MESSAGES RECEIVED** is displayed.

Information menu:

For inactive route guidance, the information menu can be requested by pressing the left rotary control .



Press the multifunction button .

A list of currently available traffic information is displayed.

More detailed information on the individual announcements can be requested in the list of current traffic information.





The scroll marks at the right edge of the display indicate that additional traffic information is available.

A selection can be made by turning the right rotary control  and pressing to confirm.

After the desired traffic information has been confirmed, the information is displayed in full. A typical traffic announcement consists of:

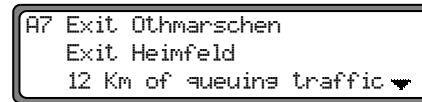
- a motorway or road number
- approximate direction information
- detailed location and direction information
- the incident
- the cause, if known



If scroll marks are visible at the right edge of the display, then more than 3 lines are used to display the traffic information. Pressing the  button, switches back to the list of current traffic information.

Navigation operation

Information during route guidance



Press the left rotary control .

The destination, the distance and the estimated time of arrival are displayed.



If a stopover has been specified, the stopover, the distance and the estimated time of arrival are displayed. The main destination can be displayed via the multifunction button .

To return to route guidance, press the left rotary control  again or wait for 8 seconds.



Requesting journey duration and kilometres travelled

During route guidance, press the left rotary control .

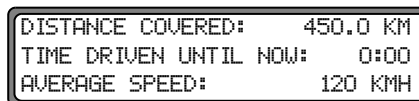

Press the multifunction button .



The journey duration, kilometres travelled and the average speed are displayed. Pressing the right rotary control  or the  button, returns to the route guidance display.

The information for journey duration, kilometres travelled and the average speed can also be requested as previously described, provided that the destination flag waves after the destination has been reached.

Displaying the route settings



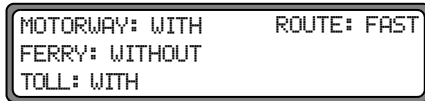

During route guidance, press the left rotary control . Press the **MOD** multifunction button.



The route settings are displayed. After 8 seconds, the system returns to the route guidance display.

Request current time



During route guidance, press the left rotary control . Press multifunction button .

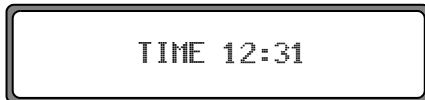

The current time is displayed. After 8 seconds, the system returns to the route guidance display.

Requesting current position

During route guidance, the current position can be requested.



Press the multifunction button .



The current position with road name (if available), degrees of longitude and latitude and the number of satellites received are displayed.

By pressing the right rotary control , the program returns to the route guidance display.

For inactive route guidance, the information menu can be requested by pressing the left rotary control .



Navigation operation

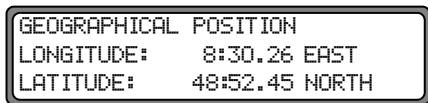

Press the multifunction button .





The geographic position is displayed.

Pressing the right rotary control  or the  button returns to the information menu.

Requesting the road list

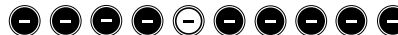
During route guidance, the planned route list can be requested.



Press the multifunction button .



The current road and the road names up to the destination are displayed. The route list can be scrolled by turning the right rotary control .

By pressing the right rotary control , the program returns to the route guidance display.

Note: After destination entry, there is a short delay until the route list is created. If the vehicle is “off road” at the moment of destination entry, the route list cannot be created until a stored road is reached.

Destination memory

Using the right rotary control , select DEST. MEMORY in the main navigation menu and press to confirm.



The destination memory contains personally stored destinations. Once stored, manual entry of the destination is no longer necessary.



Select the destination using the right rotary control  and press to confirm.

The system jumps to the route menu.

Special destinations

Menu for selecting special destinations from a specified list. Special destinations are e.g. petrol stations, airports or hospitals.



Using the right rotary control , select P.O.I. from the main navigation menu and press to confirm.



Using the right rotary control , make a selection and confirm.

- Special destinations LOCAL AREA / NEAR DESTINATION

Special destinations in the current surrounding area of the vehicle or special destinations near the destination can be selected.



Using the right rotary control , select a category and press to confirm.

Navigation operation



Destinations are listed according to proximity. The figures in kilometres relate to the direct distance (as the crow flies) between the special destination and the current location.

The arrows following the distance information indicate the distance as the crow flies to the relevant special destination (e.g. ➔ special destination lies in the direction of travel, ➔ special destination lies in the opposite direction to that of travel).

Select the desired destination using the right rotary control ●.

By pressing the left rotary control ●, information on the selected destination is listed (e.g. a hospital).



Confirm the selection using the right rotary control ●.
The system jumps to the route menu.

- Special destinations TOWN / COUNTRY
Special destinations of your choice in countries contained in the navigation CD can be selected.

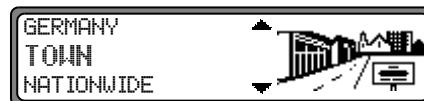

Using the right rotary control ●, select either GERMANY (see page 83), TOWN or NATIONWIDE and press to confirm.

Select TOWN

Special destinations in a specified town can be selected.



Using the right rotary control ●, select the town name and press to confirm.

Then select the town from the town selection list using the right rotary control ● and press again to confirm.



The special destinations for the selected town are displayed. Using the right rotary control , select a category and press to confirm.

A list with special destinations is displayed or if there are more than 9 entries in the list, you will be requested to enter text.



Enter the special destination and confirm. Confirm the special destination in the list displayed by pressing the right rotary control .

The system jumps to the route menu.

Note: A list of possible special destinations is displayed by pressing the right rotary control  for more than 2 seconds without having selected any letters.

Select NATIONWIDE



Using the right rotary control , select a category and press to confirm.

A list with special destinations is displayed or if there are more than 9 entries in the list, you will be requested to enter text.



Enter the special destination and confirm. Confirm the special destination in the list displayed by pressing the right rotary control .

The system jumps to the route menu.

Note: A list of possible special destinations is displayed by pressing the right rotary control  for more than 2 seconds without having selected any letters.

Navigation operation

System settings

In the main navigation menu, press the  button.
The system settings menu is requested.



Selection from

TIME,
SAVE POSITION,
GAMES,
LANGUAGE,
ANIMATION,
MEASURING UNIT,
ANNOUNCEMENT ETA,
CALCULATE EURO

can be made by turning, and confirmed by pressing the right rotary control .

- TIME
The internal system clock can be set to local time.
- SAVE POSITION
The current position can be saved and stored in the destination memory.
- GAMES
A selection of games is available.
- LANGUAGE
Language setting for the navigation system.

- ANIMATION
The display animations can be switched on or off.
- MEASURING UNIT
The display units can be changed from metres to yards.
- ANNOUNCEMENT ETA
Announcement of the estimated time of arrival can be switched on/off.
- CALCULATE EURO
Currencies can be converted into Euro or into one another.

Setting the time

In order to achieve correct navigation on routes requiring guidance under time restrictions and to calculate the estimated time of arrival, it is necessary to set the GMT time transmitted from satellites to the current time zone.



Select TIME in the system settings menu and confirm.



Using the multifunction button **24H** the time can be changed from the 24 hour to the 12 hour display.

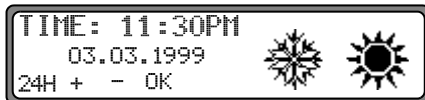

Using the multifunction buttons **+** or **-** the time is changed every half an hour.

By pressing the right rotary control **OK** or the multifunction button **OK** the time set is accepted.

The program returns to the system settings menu.

Saving the position



Select **SAVE POSITION** in the system settings menu and confirm.

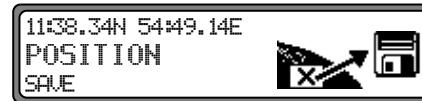

The current co-ordinates (degrees of longitude and latitude) for the position are displayed.

Confirm again by pressing the right rotary control **OK**.



Enter the name of the position.

Press the right rotary control **OK** for more than 2 seconds to confirm the name entered. To confirm, the small tick **✓** can also be marked and the right rotary control **OK** briefly pressed. The destination memory is automatically requested (see page 103).

Select the desired position in the destination memory using the right rotary control **OK** and press to confirm.

Navigation operation

Requesting the position

Request the destination memory (see page 103) and select destination using the right rotary control .

If the position is outside a digitised area, the driver is guided to the digitised route nearest to the destination. The announcement “Your destination is nearby” is given. The direction of the arrows must be followed in order to reach the destination.

Selecting a game



Select GAMES from the system settings menu and confirm.



Select a game using the right rotary control .

Setting the language



Select LANGUAGE in the system settings menu and confirm.



Select the language using the right rotary control . The language selection is accepted by pressing the control and the language is installed.

You can choose either a male or a female voice for certain languages.



Select the voice using the right rotary control . The voice is accepted and installed by pressing the control.



The system returns to the system settings menu after installation.

Animation



Select ANIMATION in the system settings menu and confirm.



It is possible to select between animation ON and OFF by briefly pressing the right rotary control . Press and hold the right rotary control  to accept the setting. The system returns to the system settings menu.

Selecting the measuring unit



Select MEASURING UNIT from the system settings menu and confirm.



Select the measuring unit using the right rotary control . The measuring unit is accepted by pressing the control. The system returns to the system settings menu.

Note: METRIC indicates calculation in metres.
IMPERIAL indicates calculation in yards.

Navigation operation

Switching announcement of the estimated time of arrival on/off



Select ANNOUNCEMENT ETA in the system settings menu and confirm.

ETA stands for Estimated Time of Arrival.



It is possible to select between announcement ETA ON and OFF by briefly pressing the right rotary control .

Press and hold the right rotary control  to accept the setting. The system returns to the system settings menu.

Calculating Euro

It is possible to convert various currencies into Euro or into one another.



Select CALCULATE EURO in the system settings menu and confirm.



To change the source currency, press multifunction button



To change the target currency, press multifunction button



The currency can be selected after pressing one of the multifunction buttons ( or ).







Select the currency using the right rotary control . The currency is accepted by pressing the control.

The program returns to the Euro calculator.

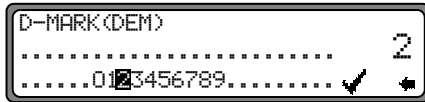

In order to perform a currency conversion, press the right rotary control .



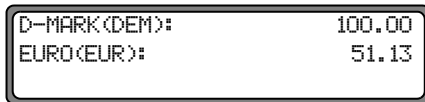

Using the right rotary control , enter the amount and confirm the entry by pressing for more than 2 seconds. To confirm, the small tick  can also be selected and the right rotary control  briefly pressed.

The result is displayed.

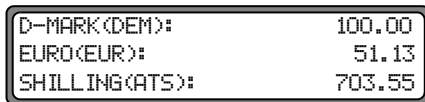

For conversion from e.g. German Marks (DEM) into Austrian Shillings (ATS), the amount in Euro (EUR) is always additionally displayed.



Press the  button to perform a new entry.

In order to quit the currency calculator, press the  button repeatedly until the required menu is selected.

Radio operation

Switching on radio mode

Press **RAD** button.

The radio is set to the previously selected waveband.

Switching on radio menu mode

In radio mode, press the **RAD** button.

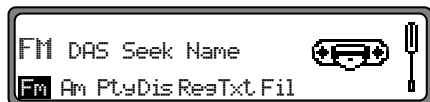

The radio menu mode is switched on and displayed. The unit switches back to radio mode if no button is pressed within the next 8 seconds.

Selecting the FM waveband

In radio menu mode, press the **Fm** multifunction button.



The last selected transmitter and plane are displayed.

By pressing several times, the planes DAS Seek Qual., DAS Seek Name, Stations FIX and Stations RDS can be selected.

- DAS Seek Qual. (see also page 138)
- DAS Seek Name (see also page 138)
- Stations FIX (see also page 138)
- Stations RDS (see also page 138)

Selecting the AM waveband

In radio menu mode, press the **Am** multifunction button.

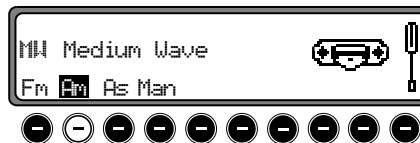

The last selected waveband and transmitter are set.

To select the wavebands MW (Medium Wave), LW (Long Wave) and SW (Short Wave), press the multifunction button **Am** repeatedly until the required waveband is selected.

Setting options for transmitter selection

The desired transmitter can be selected via dynamic autostore (FM), autostore (MW, LW), transmitter search, scan search, manual tuning, and station buttons.

Dynamic autostore (FM DAS)

In radio menu mode, press the **FM** multifunction button repeatedly until DAS Seek Qual. or DAS Seek Name is displayed.



In FM DAS mode, the receivable transmitters are displayed according to the setting via the multifunction buttons.



Set the desired transmitter by pressing the button directly below the abbreviated station designation. If the selected transmitter broadcasts several programmes/regional programmes, a submenu is automatically displayed to select the desired programme.



If a programme has previously been selected that belongs to the particular transmitter chain, the last stored programme entry will be automatically selected.

The multifunction button **->** indicates that the button can be pressed for displaying and selecting additional transmitters.

To indicate those transmitters not easily identified due to the display of advertisements or news, the abbreviation L-1... L-Z (L = Local) is used. This prevents constant switching in the lower display line. When a transmitter is selected, it is indicated by a star (e.g. L*1).

When using the unit for the first time, or following interruption of the power supply, allow for a brief waiting period so that the receiver can evaluate the transmitter signals. The display will appear incrementally as the evaluation progresses.

FM DAS transmitter search

Turn the right rotary control **●** to the left/right. The radio displays the receivable and identified transmitters in descending/ascending order.

Transmitter search MW, LW, SW

In the desired waveband (MW, LW, SW), turn the right rotary control **●** to the left/right. The radio searches for reception frequencies in descending/ascending order of frequency.

Radio operation

Scan search

In the desired waveband (FM, MW, LW, SW) press the right rotary control ; SC is displayed.

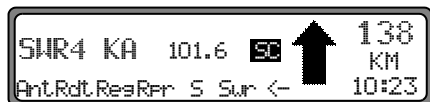

An automatic transmitter search is started. The first run is performed on an insensitive plane, all further runs on a sensitive plane. Receivable transmitters can be heard for 8 seconds. Press the right rotary control  if the received programme should be retained.

Note: For FM DAS, the scan search is performed in alphabetical order.

Programme filtering for FM DAS

You have the option of filtering various stations from the FM DAS transmitter list.

In radio menu mode, press the **Fil** multifunction button.



The individual programmes can be selected using the right rotary control . It is then possible to select between **Play** (programme not filtered) and **Skif** (programme filtered out) by

pressing the right rotary control .

In order to switch the filter function on or off, repeatedly press the multifunction button **Fil**. The filter function is switched on (Fil on) or off (No Fil).

Programme type selection (PTY)

In radio menu mode, press the **Pty** multifunction button.



Then, using the multifunction button **Pty** select the desired PTY (see also page 139).

Note: Only those PTYs can be selected that are currently available.

Once a PTY has been selected, only those transmitters can be selected in FM DAS mode that are equipped with this PTY. By selecting **NO PTY**, all transmitters will be re-displayed in FM DAS mode.

Switching PTY display on/off

Select radio menu mode.



Using the multifunction button **Dis** select either **PTY** (PTY display switched on) or **Frequency** (PTY display switched off).

Requesting/storing FM transmitters

In radio menu mode, use the multifunction button **Fm** to select the plane **Stations FIX** or **Stations RDS**.

- **Stations FIX** (see also page 138)
- **Stations RDS** (see also page 138)

Storing: 12 frequencies or programmes can be stored per waveband.

In order to store the desired transmitter or programme, press the multifunction button **1 - 6** or **7 - 12** until a signal tone sounds.



To access memory locations 7 - 12, press the **->** multifunction button.

Request: Press the **1 - 6** or **7 - 12** multifunction button. The stored transmitter is requested.

Requesting/storing MW, LW, SW transmitters

Store: 12 transmitters can be stored under multifunction buttons. Search for the desired transmitter and press the desired multifunction button until a signal tone sounds.

To access memory locations 7 - 12, press the **->** multifunction button.



Request: Press the **1 - 6** or **7 - 12** multifunction button. The stored transmitter is requested.

Radio operation

MW, LW autostore

In the desired waveband, press the **RAD** button.



Press the **As** multifunction button repeatedly until **Autostore on** is displayed.

Press the **As** multifunction button until **Seek Autostore** is displayed.

The 6 transmitters with the best reception are stored under the station buttons in order of quality.

In order to quit the autostore storage plane, use the multifunction button **As** to switch off the autostore storage plane (off). The radio switches back to the station button plane.

FM manual tuning

In radio menu mode, use the multifunction button **FM** to select the **Stations FIX** plane.



Press the **Man** multifunction button twice.

Then turn the right rotary control **●**.

100 kHz tuning steps are performed.

On the display, active manual tuning is indicated by **MAN**. After a short delay and without turning the right rotary control **●**, **MAN** disappears and manual tuning is switched off.

MW, LW, SW manual tuning

In the desired waveband, press the **RAD** button.



Press the **Man** multifunction button twice.

Then turn the right rotary control **●**.

9 kHz (MW), 3 kHz (LW) or 5 kHz (SW) tuning steps are performed.

On the display, active manual tuning is indicated by **MAN**. After a short delay and without turning the right rotary control **●**, **MAN** disappears and manual tuning is switched off.

Regionalisation

The RDS diversity function is independent of region. If the RDS diversity function should switch among various regional programmes with diverse broadcast contents, the special regional sub-programme must be selected directly.

A transmitter must first be selected in order to see if it broadcasts more than one regional programme.

Transmitters with additional regional transmitters are identified by a star (e.g. 4*).

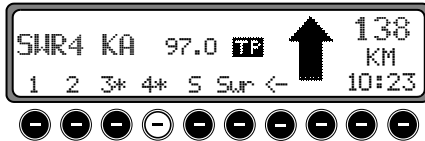

Upon selection of one of these transmitters (e.g. 4*) all receivable regional sub-programmes for this transmitter will be displayed.

Then select desired regional sub-programme (e.g. **Ka**).



If, despite RDS diversity function, the reception quality of a regional sub-programme is inferior, bear in mind that regional sub-programmes are transmitted for the most part over only a few frequencies. If the unit remains tuned to frequencies with better reception quality, there will be less drift.

Switching regionalisation on/off

Select radio menu mode.



Using the multifunction button **Res** switch the regionalisation on (on) or off (off).

Switching frequency display on/off

Select radio menu mode.



Using the multifunction button **Dis** select either **Frequency** (frequency display switched on) or **PTY** (frequency display switched off).

Radio operation

Switching radio text display on/off

Select FM radio menu mode. Using the multifunction button

Txt switch on radio text.

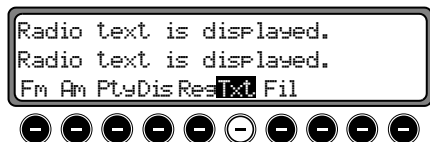

The car radio filters information transmitted by the transmitter and displays it in the form of radio text.

Radio text cannot be displayed unless the selected transmitter also transmits radio text.

Unfavourable reception conditions, including interference, can garble or even block a radio text display.

In order to quit the radio text plane, press the **RAD** button.

Note: Since information transmitted via radio text display varies constantly, we recommend tuning in the radio text only when the vehicle is stationary to avoid unnecessary distraction for the driver. This is a necessary precaution for accident prevention.

Traffic Programme (TP)

If an RDS diversity transmitter transmits TP announcements, it is possible to interrupt CD, CDC/AUX, MW, LW or SW operation or the mute function and to switch through the transmitted TP announcement. Moreover, you can listen to one FM station while having TP announcements switched through that are transmitted by another FM station.

The functionality of the traffic programme functions depends on the status of the TMC setting - TMC switched on/off. (See “Switching TMC on/off” on page 121.)

When TMC is switched off:

- There are two ways to select a TP transmitter:
 - **automatic tracking**
 - **direct programming**

Automatic tracking always uses the FM station currently being received as the TP transmitter. If the selected FM station has poor reception quality or cannot function as a TP transmitter, the unit applies specified criteria to search for a new TP transmitter.

Direct programming enables a TP transmitter to be programmed that is not the FM station being received. For example, one FM station can be received while TP announcements transmitted by another FM station are switched through.

If the programmed TP transmitter reception is poor, the unit switches to automatic tracking until the programmed TP transmitter is receivable.

When TMC is switched on:

- With TMC, the unit is capable of selecting a suitable traffic programme transmitter automatically. If possible, a TMC station is selected as the traffic programme transmitter. The selected TMC station usually offers the best traffic information for the region in which you are travelling. If no TMC station is available, the traffic programme transmitter with the strongest signal is selected.

If an RDS transmitter is equipped with a traffic programme, this is indicated on the display by TP.

An inverse TP TP appears on the display to indicate that the traffic programme is active.

Activating/quitting the TP menu

Activating: Press the TP button (traffic announcements cannot be transmitted).



Press the TP multifunction button.

Quitting: Press the TP button or the TP menu will be automatically terminated after 8 seconds without actuation.

Switching TP on/off

In all modes and wavebands, TP can be switched on/off by pressing the TP button for more than 2 seconds.

TP can also be switched on/off in the TP menu.

Switching on: To switch on TP in the TP menu, press the TP multifunction button repeatedly until TP on is displayed.



Switching off: To switch off TP in the TP menu, press the TP multifunction button repeatedly until TP off is displayed.

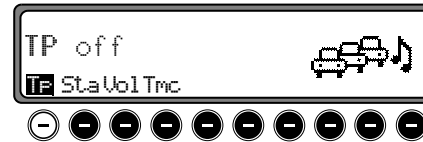

TP is switched off after returning to normal display.

Radio operation

Selecting automatic tracking

Only applies when TMC is switched off.

In all modes and wavebands, automatic tracking can be switched on by pressing the **TP** button for more than 2 seconds.

To switch on automatic tracking in the TP menu, press the **TP** multifunction button repeatedly until TP on is displayed.



Attention: If a TP transmitter has already been programmed directly, it will once again be selected as the TP transmitter.

Selecting/deleting direct programming

Only applies when TMC is switched off.

Activate the TP menu.

Selecting: Press the **Sta** multifunction button.



Using the right rotary control, select the desired TP transmitter. After a short delay and without actuation, the

selected transmitter is accepted.

Deleting: Press the **Sta** multifunction button.



Using the right rotary control, select Autoselect and press to confirm. After a short delay and without actuation, the direct programming is deleted.

Quit the TP menu.

Switching mute on/off

After selecting a TP or EON transmitter, the mute function can be activated by briefly pressing the **TP** button.

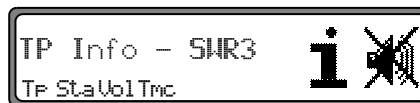

Thereafter, only traffic announcements and navigation announcements will be switched through. After pressing the **TP** button again, muting is cancelled.

Interrupting TP announcements

During a TP announcement, briefly press the **TP** button. The announcement currently being broadcast will be interrupted and the system will automatically return to the previously selected mode.

TP announcement volume

Activate the TP menu. Press the **Vol** multifunction button.



Using the right rotary control , four different settings (0 - 3) can be selected. This means that the volume can be raised to a fixed value according to the setting.

- Setting 0 - no volume increase
- Setting 1 - slight volume increase
- Setting 2 - medium volume increase
- Setting 3 - large volume increase

Switching TMC on/off

Note: You can find further information on TMC under “Dynamic navigation with TMC” on page 97.

Activate the TP menu.

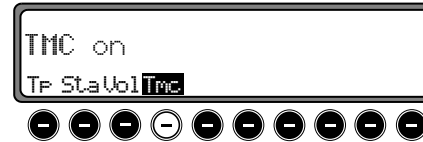

Switching on:

Press the **Tmc** multifunction button repeatedly until TMC on is displayed.

If TMC is switched on, a traffic programme transmitter cannot be selected freely. A TMC station is selected by the unit, provided one can be received. This transmitter then corresponds to the traffic programme transmitter.

Switching off:

Press the **Tmc** multifunction button repeatedly until TMC off is displayed.

If TMC is switched off, a traffic programme transmitter can be selected freely.

Note: Dynamic navigation functions (dynamic route, traffic information) cannot be selected or called up.

Radio operation

Display for TMC stations

If a radio station transmits TMC information in addition to the radio programme, this is indicated on the display by the abbreviation TMC. TMC information is received and analysed by the navigation system. The reception of traffic announcements is free of charge.

TMC is shown in **normal typeface**:

The instantaneously selected station is a TMC station. TMC is switched off.



TMC is shown in **inverted typeface**:

The instantaneously selected station is a TMC station. TMC is switched on.



Telephone mute function

The telephone characteristics can be set in the PSM menu (see page 130) if a telephone system is installed in the vehicle and the mute function lead for the car telephone is connected to the car radio.

If **Mute** is selected, the radio is switched to mute if a call is received.

If **Audio Signal** is selected, the telephone call is connected through the radio unit if a call is received (vehicle ignition must be switched on).

However, this is only possible if, in addition to the telephone, a handsfree unit with loudspeaker output is installed and connected to the radio. In both cases, **PHONE** is displayed.



Compact Disc (CD) instructions

Sound interruptions may occur if the CD is dirty. In order to ensure optimum tone quality, please note the following:

- Always touch the CD at the edges only. Keep the disc clean and never touch the surface.
- Never stick anything to the CD.
- Protect the CDs against direct sunlight and from heat sources such as heaters etc.
- Before playing, clean the CD with a commercially available cleaning cloth, wiping from the centre outwards. Solvents such as petrol, thinners or other commercially available cleaners and anti-static sprays must not be used.

When playing a CD-R (Recordable)

You can play back your original CD-Rs on this receiver.

- Before playing back CD-Rs, read their instructions or cautions carefully.
- Some CD-Rs recorded on CD recorders may not be played back on this receiver because of their disc characteristics, and of the following reasons:
 - Discs are dirty or scratched.
 - Moisture condensation occurs on the lens inside the unit.
 - The pickup lens inside the CD player is dirty.
- Use only “finalized” CD-Rs.
- CD-RWs (Rewritable) cannot be played back on this receiver.
- Do not use CD-Rs with stickers or sticking labels on the



surface. They may cause malfunctions.

- Attention:**
- Do not insert 8 cm CDs (single CDs) into the loading slot. (Such CDs cannot be ejected.)
 - Do not insert any CD of unusual shape — like a heart or flower; otherwise, it will cause a malfunction.

Inserting/ejecting CDs

Press  button; the display folds downwards and the CD slot becomes visible. Insert the disc into the CD slot with the printed side upwards. The unit pulls in the CD automatically and begins to play the disc from the first track. Then fold the display up again.

After playing the last track, the unit automatically begins to play the first track of the CD again.

If there is already a CD in the slot, press the  button. If CD changer/AUX operation was last selected, use the multi-function button  to switch to CD operation.



To eject a CD, press and hold  button; the display folds downwards and the CD is ejected. Remove the CD. Then fold the display up again.

Attention: The CD is not ejected when the unit is switched off but remains in the CD slot.

CD operation

Track skip - forwards/backwards

Press the multifunction button  (forwards) or  (backwards).



By pressing the multifunction button repeatedly, several tracks can be skipped over in forward or reverse directions. The unit switches to the first track when the last track has been reached. Analogously, it switches from the first track to the last track.

If the track has been playing for longer than 10 seconds when the track skip function is triggered, the device returns to the beginning of the track.



Intro scan

Press the right rotary control , SC appears on the display.



All following CD tracks are played for 10 seconds each. Press the right rotary control  again to terminate intro scan.

Fast forward/rewind

By pressing the multifunction button  (audible) fast forward is activated, or by pressing the multifunction button  (audible) fast rewind is activated.



Fast forward/rewind is terminated by releasing the multifunction button.

Random play

By pressing the multifunction button  random play is activated. The tracks on the current CD are then played in random order. The prompt Rnd is displayed inversely.



After pressing the multifunction button  again, the random play function is deactivated.

Repeating a track

By pressing the multifunction button **RPT** the track repeat function is switched on. The prompt **RPT** is displayed inversely.

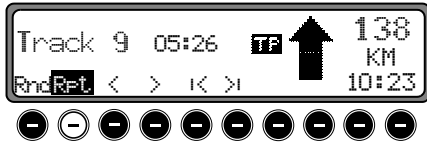

After pressing the multifunction button **RPT** again, the track repeat function is switched off.

Number of tracks and total playing time

In CD mode, press the **CD** button. By pressing the multifunction button **Trk** the elapsed time for the tracks already played is displayed briefly.



By pressing the multifunction button **Tt1** the number of tracks and the total playing time of the current CD are displayed briefly.

Temperature protection circuit

A temperature protection circuit is utilised in this unit in order to protect the laser diode against overheating.

When the protection circuit is requested, **TEMP** is displayed for 8 seconds and the unit switches back to radio operation.

The single CD operation can be requested again after a short cooling phase. However, if the temperature is still too high, the unit again switches back to radio operation.

CD changer operation

Operational readiness of CD changer

You can connect any JVC CD changer (CH-X series except CH-X99) to this unit using JVC CD changer adaptor KS-U16K (purchased separately.) Once connections are completed, it is ready for operation when a CD magazine is inserted into the CD changer. Further operation is performed via KD-NX1R.

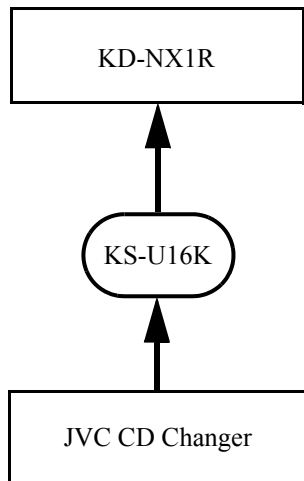

Note: When connecting your CD changer, refer to the Instruction manuals supplied for your CD changer and KS-U16K.

CD magazine - load/unload

To remove the CD magazine, open the sliding cover on the changer and press the eject button. The magazine is ejected and can be removed.

Attention: Incorrectly inserted CDs will not be played.

Playing CDs

Press **CD** button. If the unit was last set to CD changer operation or there is no CD (or navigation CD) in the CD drive, the CD changer menu is now active.

If CD operation was last selected, use the multifunction button **CD** to switch to CD changer operation.

The last CD to be played is played from the position at which it was left before switching off.

Stored CDs can be selected by turning the right rotary control **●**. Loading CD **X** is displayed during the selection time. The magazine compartment number of the CD and the number of the current track on the selected CD are then displayed.

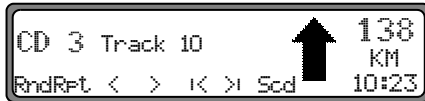

If no CD is present in the selected magazine compartment (e.g. compartment 2), **NO CD 2** is displayed briefly.

After playing the last track of a CD, the next CD is automatically selected and played.

Track skip - forwards/backwards

Press the multifunction button **>|** (forwards) or **|<** (backwards).

By pressing the multifunction button repeatedly, several tracks can be skipped over in forward or reverse directions. The unit switches to the first track when the last track has been reached. Analogously, it switches from the first track to the last track.

If the track has been playing for longer than 10 seconds when the track skip function is triggered, the device returns to the beginning of the track.

Intro scan

Press the right rotary control **●**, **SC** appears on the display. All following CD tracks are played for 15 seconds each. Press the right rotary control **●** again to terminate intro scan.

CD changer operation

Fast forward/rewind

By pressing the multifunction button **>** (audible) fast forward is activated, or by pressing the multifunction button **<** (audible) fast rewind is activated.

Fast forward/rewind is terminated by releasing the multifunction button.

Random play

By pressing the multifunction button **Rnd** random play is activated. The tracks on the current CD are then played in random order. The prompt **Rnd** is displayed inversely.

After pressing the multifunction button **Rnd** again, the random play function is deactivated.

Repeating a track

By pressing the multifunction button **Rpt** the track repeat function is switched on. The prompt **Rpt** is displayed inversely.

After pressing the multifunction button **Rpt** again, the track repeat function is switched off.

Number of tracks and total playing time

In CD mode, press the **CD** button. By pressing the multifunction button **Trk** the elapsed time for the current track is displayed briefly.

By pressing the multifunction button **Ttl** the number of tracks and the total playing time of the current CD are displayed briefly.

PSM (Preferred Setting Mode) menu

Requesting/quitting PSM menu

After requesting the PSM menu, the following basic settings can be selected on two planes according to your personal preference.

First plane:

- Gal - speed-dependent volume control
- Tel - telephone characteristics
- Col - display colour setting
- Lcd - display setting
- Led - LED setting
- M/S - reception optimisation setting

Second plane:

- Nav - navigation announcement setting
- Aux - aux input setting
- Cmf - compass display setting
- BeU - signal tone volume setting

The PSM menu is requested by pressing the **SEL** button for more than 2 seconds.



In order to access the second plane of the PSM menu, press the **→** multifunction button.

Press the **SEL** button again to quit the PSM menu.

PSM (Preferred Setting Mode) menu

GAL (Gal) setting

The GAL is a car radio control circuit, which automatically adjusts the car radio volume according to vehicle speed. This results in compensation of the driving noise produced at higher speeds.

Request the PSM menu. Press the **Gal** multifunction button. Using the right rotary control  select either 0 or +15.

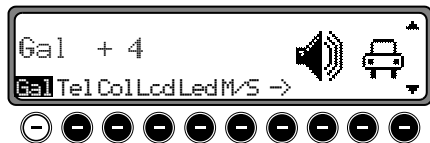

With the GAL setting, the start of volume adjustment can be specified according to vehicle speed.

The setting is stored automatically.

Explanation:

- 0 - no volume increase
- +1 - volume is increased at low speed
- +15 - volume is increased at a higher speed

Telephone mute characteristics (Tel)

If a telephone system with handsfree unit is installed in the vehicle, the telephone conversation can be conducted via the car radio system. Thus, installation of the additional loudspeaker which is normally required is not necessary. However, the signal cables (AF - telephone input and earth - telephone input) must be connected to the car radio.

For selection, request PSM menu. By pressing the multifunction button **Tel** select either **Audio Sys.** or **Mute**.



- **Mute** - Telephone mute mode
- **Audio Sys.** - Telephone conversation via car radio

(Col) display colour setting

This setting is used to choose between two illumination colours.

For selection, request PSM menu. By pressing the multifunction button **Col** select either red or yellow.



The setting is stored automatically.

Display setting (Lcd)

The display setting allows you to select among three different display versions.

- Negative display (*negativ*)
- Positive display (*positiv*)
- Automatic display (*automatic*) - the display will appear negative or positive depending on vehicle illumination.

For selection, request PSM menu. By pressing the multifunction button **Lcd** select either *negativ*, *positiv* or *automatic*.

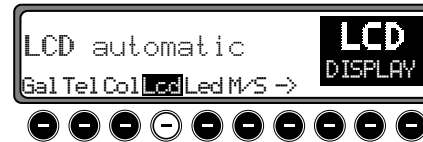

The setting is stored automatically.

PSM (Preferred Setting Mode) menu

LED setting

The flashing of the LED (flashes when the ignition is switched off) can be switched on or off using this function.

Request the PSM menu. By pressing the multifunction button

Led select either **blinking** (LED switched on) or **off** (LED switched off).

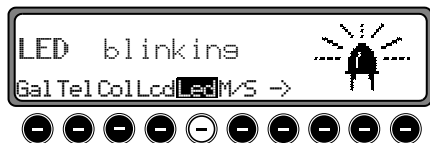

The setting is stored automatically.

Setting reception optimisation (M/S)

Three different reception optimisation settings can be selected in order to suppress reception-dependent interference and reflections.

Request the PSM menu. By pressing the multifunction button

M/S select either **Stereo**, **Mono** or **Auto**.



- **Auto** - Setting for normal operation - i.e., the system switches from stereo to mono and back depending upon reception location (provides the optimum setting for almost all reception areas).
- **Stereo** - Setting for exceptional reception conditions - i.e. the unit is constantly set to stereo.
- **Mono** - Setting for reception conditions in which reflections constantly occur - i.e., the unit is set constantly to mono.

The setting is effective immediately and is also retained on switching off.

PSM (Preferred Setting Mode) menu

Setting navigation announcements (Nav)

With this function you can select how you wish to hear navigation announcements.

- **only** - The audio source currently being listened to is switched off and only navigation announcements are heard.
- **mixed** - The volume level of the audio source currently being listened to is decreased. The navigation announcement is set to the same volume level as the previously heard audio source but still adjustable within a range of +/-6 dB. If the audio source volume is then changed, the navigation announcement volume is adjusted accordingly.
- **independ** - The audio source being listened to and the navigation announcement can be set to various levels.

For selection, request PSM menu. By pressing the multifunction button **→** request the second plane of the PSM menu. Using the multifunction button **Nav** select either **only**, **mixed** or **independ**.



The setting is stored automatically.

AUX input (Aux)

This can be used to switch on the CD changer AF connections if no CD changer is connected. An external unit (MD player, etc.) can then be connected.

For selection, request PSM menu. By pressing the multifunction button **→** request the second plane of the PSM menu. Using the multifunction button **Aux** select either **AUX Mode on** (on) or **Aux Mode off** (off).



The setting is stored automatically.

In CD mode, press the **Aux** multifunction button in order to select AUX mode.

PSM (Preferred Setting Mode) menu

Compass display

If route guidance is not active, it is possible to display a compass on the right side of the display.

For selection, request PSM menu. By pressing the multifunction button **→** request the second plane of the PSM menu. Using the multifunction button **CMF** select either **Show COMPASS** (compass is displayed) or **Hide COMPASS** (compass is not displayed).

If the compass display is switched off, 9 multifunction buttons are assigned transmitter abbreviations in FM DAS mode (route guidance not active).



The setting is stored automatically.

Signal tone volume

The volume of signal tones (e.g. storage confirmation) can be set using this function.

For selection, request PSM menu. By pressing multifunction button **→** request the second plane of the PSM menu.

Press the **BeU** multifunction button. Using the right rotary control **0** select either **0** (quiet) or **+5** (loud).



The setting is stored automatically.

Removal/installation instructions

A universal bracket for DIN installation slots is integrated into this car radio. An installation frame is not required. The unit is inserted into the installation slot and secured with the slides supplied.

Complete the electrical connections. Then push the unit into the installation slot. Subsequently, push the slides into the apertures in the front of the unit to the first detent position (Figure (A)). Now lock the radio by pulling both slides, as shown in Figure (B). Subsequently, remove the slides.

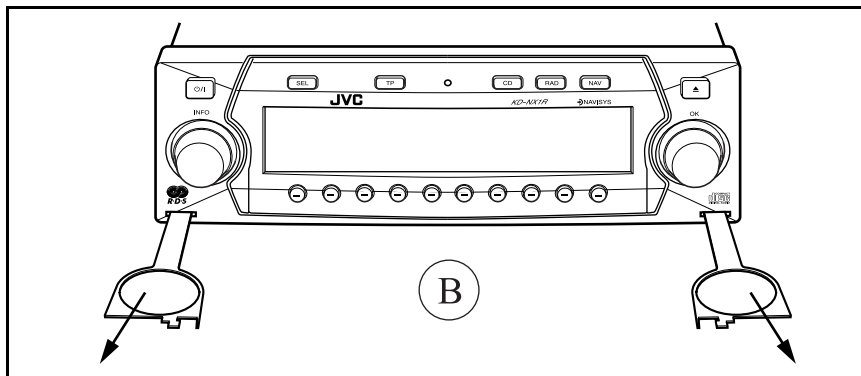
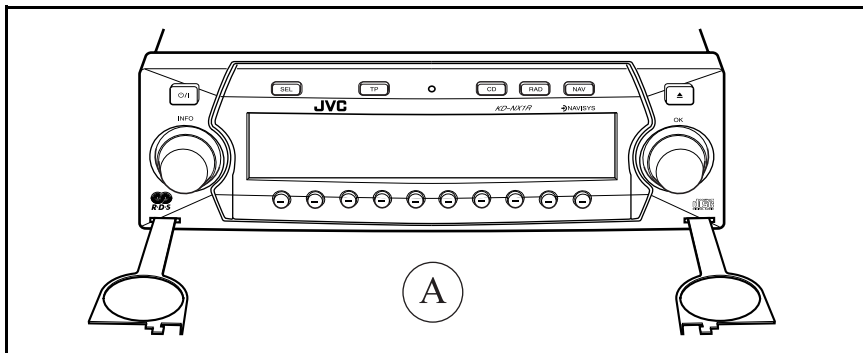

Removal/installation instructions

For removal, the unit must first be unlocked. For this purpose, push in both slides to the second detent position, as shown in Figure (A). Subsequently, withdraw the unit with both slides. (Figure (C)). Then remove the slides by pressing the springs on the right and left sides of the unit.

If the unit has been installed in another vehicle, the unit's springs may have to be adjusted before installation. To adjust the springs, push in the slides as shown in Figure (D) and then adjust as shown in Figure (E) (press the slide lightly in direction 1 and simultaneously move the slide in direction 2).

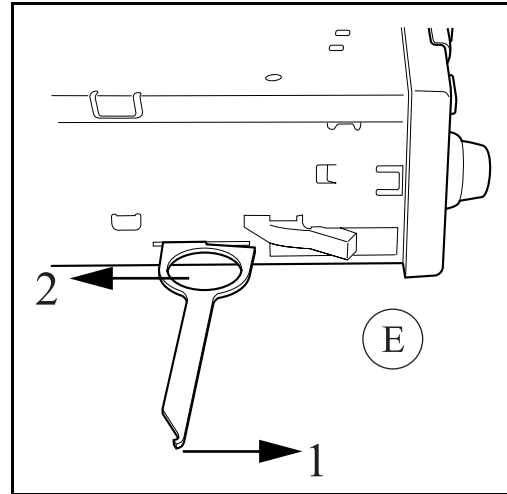
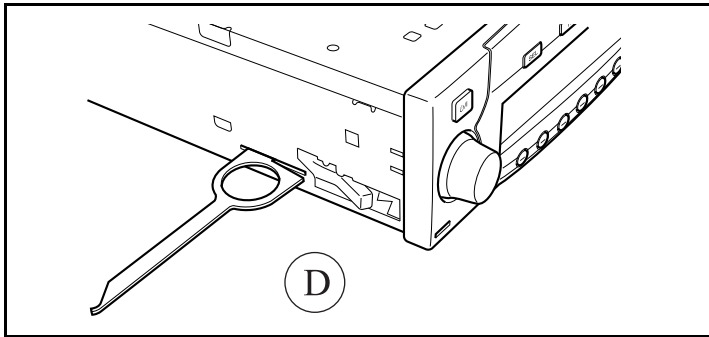
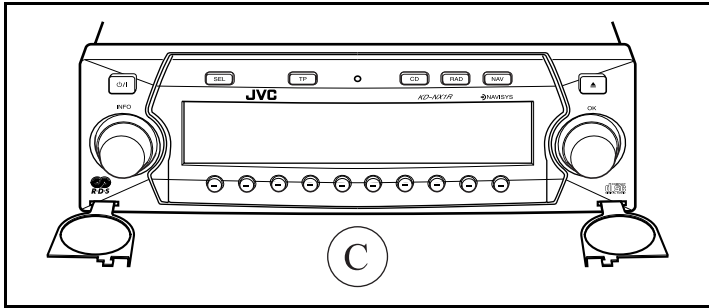

General instructions

RDS SYSTEM

This car radio is capable of receiving RDS signals (RDS = Radio Data System) in the VHF range. RDS is a technique which enables the transmission of inaudible additional information in the VHF broadcasting range. This means that the transmitter broadcasts information which can be evaluated by the car radio.

DAS Seek Qual. plane

In the **DAS Seek Qual.** plane, all receivable and identifiable RDS programmes are arranged in a list according to quality. The dynamic autostore, search and scan search functions fall back upon this list.

DAS Seek Name plane

In the **DAS Seek Name** plane, all receivable and identifiable RDS programmes are alphabetically arranged in a list according to name. The dynamic autostore, search and scan search functions fall back upon this list.

Stations Fix plane

In the **Stations FIX** plane, frequencies can be assigned to the station buttons. RDS evaluation does not take place. The search on **Stations FIX** is applicable to FM manual tuning (see page 116).

Stations RDS plane

In the **Stations RDS** plane, only identified RDS stations can be stored. The unit constantly switches to the best receivable transmission frequency for the station. During the search on **Stations RDS** the unit only stops at identifiable stations.

PTY (Programme Type)

Specific types of programme, such as e.g. sport, pop music, classical music etc., can be selected using the PTY function.

The PTY is broadcast by the RDS transmitter, provided that the transmitter is equipped with this function. The selected transmitter programme type can be displayed or a search for a specific PTY transmitter can be performed.

Examples of programme types are:

NEWS	News services
POP M	Pop music
AFFAIRS	Politics and current affairs
ROCK M	Rock music
INFO	Special word programme
SCIENCE	Science
EDUCATE	Learning and further education
LIGHT M	Light music
DRAMA	Radio plays and literature
CLASSICS	Classical music
CULTURE	Culture, church and society
EASY M	Easy listening
VARIED	Light entertainment
SPORT	Sport
OTHER M	Special music programmes
WEATHER	Weather report
FINANCE	Financial information
CHILDRG	Children's programmes
SOCIAL	Social reports
RELIGION	Religious reports

PHONE IN	Interviews
TRAVEL	Travel reports
LEISURE	Leisure reports
JAZZ	Jazz music
COUNTRY	Country music
NATION M	National folk music
OLDIES	Oldies
FOLK	Folk music
DOCUMENT	Documentaries
NO PTY	No PTY

Technical data

AUDIO AMPLIFIER SECTION

Maximum Power Output:

Front: 30 W per channel

Rear: 30 W per channel

Continuous Power Output (RMS):

Front: 12 W per channel into 4 Ω , 40 Hz to 20 000 Hz
at no more than 0.8% total harmonic distortion.

Rear: 12 W per channel into 4 Ω , 40 Hz to 20 000 Hz
at no more than 0.8% total harmonic distortion.

Load Impedance: 4 Ω (4 Ω to 8 Ω allowance)

Tone Control Range: Bass : ± 10 dB at 100 Hz
Treble : ± 10 dB at 10 kHz

Frequency Response: 40 Hz to 20 000 Hz

Signal-to-Noise Ratio: 70 dB

Line-In Level/Impedance: 1.0 V/20 k Ω

Line-Out Level/Impedance: 3.0 V/20 k Ω load (full scale)

TUNER SECTION

Frequency Range: FM: 87.5 MHz to 108.0 MHz
AM: (SW) 5 800 kHz to 6 250 kHz
(MW) 531 kHz to 1 620 kHz
(LW) 153 kHz to 282 kHz

[FM Tuner]

Usable Sensitivity: 13.3 dBf (1.2 μ V/75 Ω)

Alternate Channel Selectivity (400 kHz):
65 dB

Frequency Response: 40 Hz to 15 000 Hz

Stereo Separation: 35 dB

Capture Ratio: 1.5 dB

[SW Tuner]

Sensitivity: 20 μ V

[MW Tuner]

Sensitivity: 20 μ V

Selectivity: 60 dB

[LW Tuner]

Sensitivity: 50 μ V

CD PLAYER SECTION

Type: Compact Disc Player
Signal Detection System: Non-contact optical pickup (semi-conductor laser)
Number of channels: 2 channels (stereo)
Frequency Response: 20 Hz to 20 000 Hz
Dynamic Range: 90 dB
Signal-to-noise Ratio: 92 dB

GENERAL

Power Requirement:
Operating Voltage: DC 14.4 V (11 V to 16 V allowance)
Ground System: Negative ground
Allowable Operating Temperature: 0°C to 40°C
Dimensions (W x H x D):
Installation Size: 182 mm x 53 mm x 159 mm
Panel Size: 188 mm x 59 mm x 15 mm
Mass: 1.7 kg (excluding accessories)

ACCESSORIES

Instructions
Installation/Connection Manual
Warranty card
Navtech end user license agreement
Registration card
Helpline card
Service network
Code card
ISO cable
Single lead for reverse sensing
Mounting bolt
Soft case
Hook (2 pieces)
GPS antenna
CD-ROM

Design and specifications subject to change without notice.



JVC
VICTOR COMPANY OF JAPAN, LIMITED

JVC

NAVIGATIONSSYSTEM/CD-RECEIVER
NAVIGATION/CD RECEIVER
AUTORADIO CD/SYSTEME DE NAVIGATION
SINTOAMPLIFICATORE CON RIPRODUTTORE DI NAVIGATION/CD
SISTEMA DE NAVEGACION/RECEPTOR DE CD
NAVIGATIESYSTEEM/CD-RECEIVER
NAVIGATIONSSYSTEMET/CD-MODTAGER
NAVIGATIONSSYSTEMET/CD-SPELARE MED MOTTAGARE

KD-NX1R



COMPACT
disc
DIGITAL AUDIO

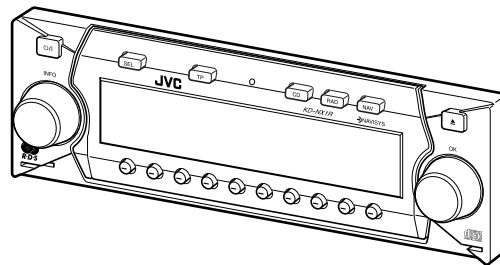

*Einbau/Anschlußanleitung
Installation/Connection Manual
Manuel d'installation/raccordement
Manuale d'installazione/collegamento
Manual de instalación/conexión
Handleiding voor installatie/aansluiting
Installations-/tilslutningsmanual
Installations/anslutningshandbok*

Wir möchten Ihnen danken, daß Sie sich für eines unserer JVC-Produkte entschieden haben.
Ehe Sie diese Anlage an die Stromversorgung anschließen, lesen Sie bitte diese Bedienungsanleitung sorgfältig und gründlich durch,
um so eine optimale Anlagenleistung zu erzielen, und heben Sie diese Bedienungsanleitung auf, damit Sie in Zukunft darin
nachlesen können.

We would like to thank you for purchasing one of our JVC products.
Before operating this unit, read this manual carefully and thoroughly to obtain the best possible performance from your unit, and
retain this manual for future reference.

Nous vous remercions d'avoir acheté un de nos produits JVC.
Avant d'utiliser cet appareil, lisez attentivement ce mode d'emploi afin d'obtenir les meilleures performances de l'appareil, et
conservez-le à titre d'information.

Nel ringraziarLa per aver scelto un prodotto JVC, ci auguriamo che possa essere pienamente soddisfatto della Sua scelta.
Ai fini dell'ottenimento delle migliori prestazioni, La invitiamo a leggere con attenzione il presente manuale d'istruzioni prima di
collegare ed accendere l'impianto.

Le agradecemos la adquisición de este producto JVC.
Como primer paso, por favor lea detenidamente este manual para comprender a fondo todas las instrucciones y obtener un máximo
disfrute de esta unidad. Guarde este manual para futuras consultas.

We danken u voor de aanschaf van een van onze JVC-producten.
Lees deze gebruiksaanwijzing aandachtig en in zijn geheel door alvorens u deze eenheid gaat gebruiken. Alleen zo kunt u het beste
uit uw apparatuur halen. Bewaar deze gebruiksaanwijzing zodat u deze in de toekomst kunt raadplegen.

Tak fordi du har købt et af JVC's produkter.
Inden du tager anlægget i brug, bør du omhyggeligt gennemlæse denne vejledning for at få det bedste ud af anlægget. Gem
vejledningen til eventuel senere brug.

Tack för ditt köp av en av våra JVC-produkter.
Läs denna handbok noga innan du använder enheten, för att kunna utnyttja den på bästa möjliga sätt, och spar handboken för
framtida bruk.

Einbau/Anschlußanleitung

DEUTSCH

Installation/Connection Manual

ENGLISH

Manuel d'installation/raccordement

FRANÇAIS

Manuale d'installazione/collegamento

ITALIANO

Manual de instalación/conexión

ESPAÑOL

Handleiding voor installatie/aansluiting

NEDERLANDS

Installations-/tilslutningsmanual

DANSK

Installations/anslutningshandbok

SVENSKA

1. “Symbols used in the Installation/Connection Manual” on page 25
2. “Safety and installation instructions” on page 25
3. “Connection diagram for the navigation system” on page 26
4. “Installation of the GPS antenna” on page 27
5. “Connecting the reverse signal” on page 29
6. “Connecting the speed signal (GAL) for the speedometer/speedometer cable” on page 29
7. “Installing and commissioning KD-NX1R” on page 34
8. “Using GPS for the first time, and sensors” on page 34
9. “Installation of the Navigation Software” on page 36
10. “Calibration” on page 37
11. “Service Mode” on page 39
12. “Connections” on page 47

1. Symbols used in the Installation/Connection Manual



denotes instructions which are important for your safety and the safety of others.



denotes instructions which are important for the installation and function of the unit.

2. Safety and installation instructions



The installation of KD-NX1R should only be carried out by a specialist.

- Disconnect the vehicle battery before installation of the unit.

Installation/Connection Manual



Note the safety instructions of the vehicle manufacturer (airbags, immobilisers etc.).

- When routing the cables, ensure that they cannot become jammed, kinked or ripped out.
- Before installation, park the vehicle in a safe and level place and remove the ignition key.
- If using branch connections, it is important to note the relevant cable section.

3. Connection diagram for the navigation system

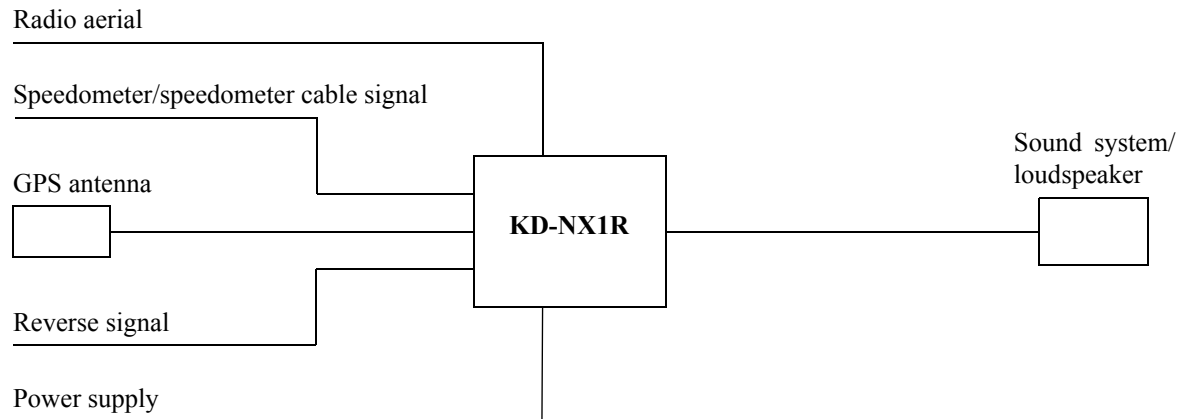

Note: The various connection options are described in detail on page 47.

4. Installation of the GPS antenna



People with pacemakers should avoid physical contact with the magnetic antenna and should not carry the antenna on their person, as this may affect the function of the pacemaker.

Keep the magnetic antenna away from data storage media (disks, credit cards, magnetic cards etc.) and electronic and precision engineering equipment, as this may cause data to be deleted.

Do not use the antenna in areas at risk of explosion.

It is important to secure the antenna so that it cannot become detached in a collision or sudden brake manoeuvre.

Possible installation positions

- **Outside the vehicle**

- a. Attach the antenna to a flat, pre-washed metal surface.
- b. Then guide the antenna cable into the vehicle interior.



The maximum vehicle speed for the antenna if magnetically attached is 180 km/h. The antenna must be removed or specially secured at higher speeds.

The antenna is not suitable for car-wash facilities.

- **Inside the vehicle**



The antenna can only be installed on a non-metallised windscreen.



When selecting the installation position, ensure that the antenna has a clear view of all directions, and that it is not covered by the windscreen wipers. Obstructions caused by the bonnet, window crossbeams and roof should be avoided as far as possible.

Installation/Connection Manual

- a. Secure the antenna to the base plate (1) with magnets.
- b. Remove protective strip from top of adhesive tape (2) and stick to the centre of the base plate underside.
- c. Remove protective strip from bottom of adhesive tape (2) and stick the antenna and base plate onto the vehicle console beneath the windscreen at the installation position.

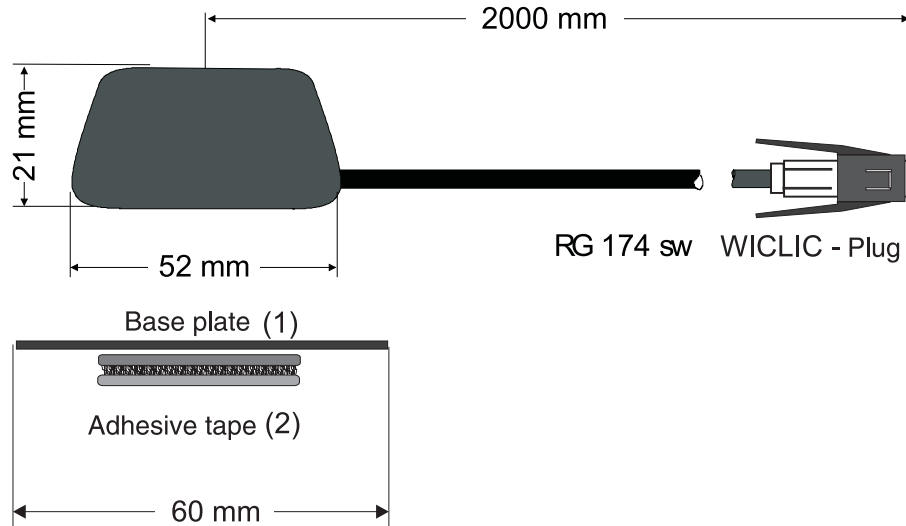

- ☞ GPS reception can be affected by screens with screen antenna, windscreen heating or thermally insulated screens. Some thermally insulated screens are coated with titanium or silver oxide. Installation of the GPS antenna in the vehicle interior can considerably impair the function of the navigation system.

5. Connecting the reverse signal

If the switch on the gearbox or shift linkage is accessible:

- Connect a separate lead to the activated contact.
Connect the lead to socket A pin 2.
- Low - level = earth, high - level 12 V - 16 V**

If the switch is not accessible:

- Check which lead is routed to the reversing lamp. Then, if necessary, remove the inner cover for the reversing light.
Connect a separate lead to the activated lead of the reversing lamp and connect to socket A pin 2.

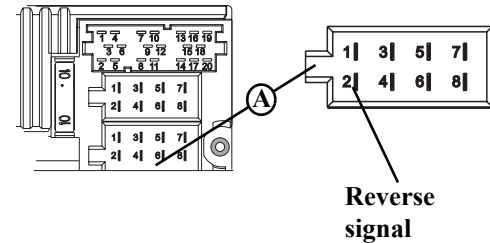

6. Connecting the speed signal (GAL) for the speedometer/speedometer cable

Electronic speedometer

- Remove the signal from the speedometer, extend and connect to socket A pin 1.

 Depending on the vehicle equipment, the lead for the GAL signal is usually connected to the DIN - ISO plug of the car radio. The assignment of the DIN - ISO plug may vary depending on the vehicle type.

- Minimum requirement for the signal:
0 Hz - 4 kHz/square-wave signal (no inductive sensor)
Low - level < 1.5 V, high - level 5 V - 16 V

 If you do not know the exact installation position/location of the speed signal, please consult the vehicle manufacturer.

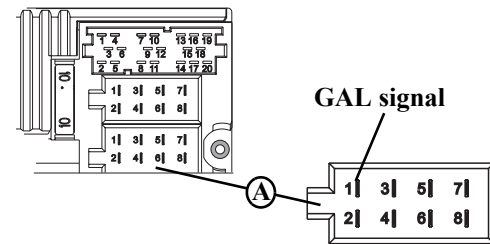

Installation/Connection Manual

Mechanical speedometer with integrated speed sensor in the speedometer cable

- Remove the signal from the speed sensor, extend and connect to socket A pin 1.
- Minimum requirement for the signal:
0 Hz - 4 kHz/square-wave signal (no inductive sensor)
Low - level < 1.5 V, high - level 5 V - 16 V

 If you do not know the exact installation position/location of the speed signal, please consult the vehicle manufacturer.

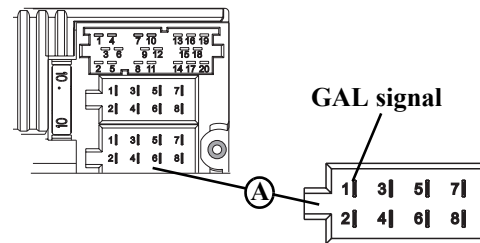

Mechanical speedometer without speed sensor in the speedometer cable

A speed sensor which generates a digital, speed-dependent signal must be installed in the speedometer cable.

The VDO adapter 2152.30300000 or a vehicle-specific adapter which satisfies the minimum requirements can be used. The VDO speed sensor is suitable for direct installation on the gearbox (no further installation parts required) or in the speedometer cable (in conjunction with additional universal installation parts).

 If the sealed speedometer cable is released, a correct display cannot be guaranteed. Incorrect installation leads to improper functioning of the navigation system or of the speedometer.

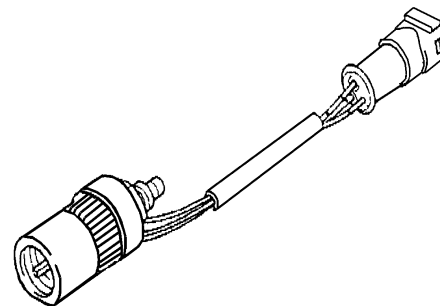

Installing the speed sensor directly on the gearbox

- Release the speedometer cable and screw speed sensor onto gearbox. Screw released speedometer cable onto the speed sensor and connect the wires.

Wire connections for the speed sensor

- Brown - earth (terminal 31)
- Black - power supply (terminal 15), 9 - 16V, 30 mA
- Blue/red - signal for socket A pin 1

Installing the speed sensor in the speedometer cable

In order to install the speed sensor, the speedometer drive cable must be cut in one even piece for insertion of the speed sensor. When removing the speedometer cable from the vehicle, ensure that the location of the evenly running piece is established and marked accordingly.

Installation is illustrated without reference to any specific vehicle. In addition to the sensor, the following VDO universal parts are required:

1 x connecting piece	1040 1300 025	(VDO part number)
2 x knurled nuts	1040 1000 003	(VDO part number)
2 x hose sleeves	1040 1000 031	(VDO part number)
2 x dogs	1040 1000 049	(VDO part number)
2 x friction washers	1040 0900 003 300	(VDO part number)
2 x fuel washers 4.0	KN07.0570.18	(VDO part number)
2 x washers	KN11.1904.122	(VDO part number)

An appropriate, complete kit from VDO (part number X 39397106191) can also be used.

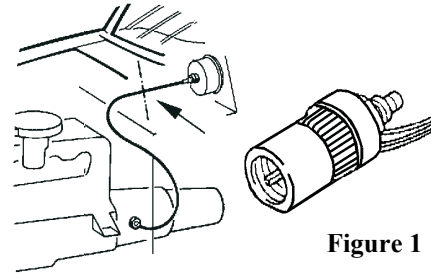
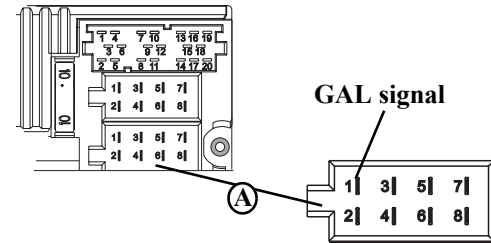

Figure 1

Installation/Connection Manual

Recommended tool: Cable installation tool for speedometer cables from VDO, order number: 1999.10.13.000.110

If you require vehicle-specific parts, please consult the vehicle manufacturer or your nearest VDO branch.

- Using a metal saw, saw into the cable approx. 1 mm at right angles to the profile and break off (Figure 3).
- Then cut the cable in the centre with side-cutting pliers (Figure 4).
 - ☞ For protective hoses with wire netting, the hose and flex cable can be cut directly with the side-cutting pliers.
- Shorten the protective hose again at both ends up to the plastic sheathing. Check whether the ends of the flex cable still engage in the speedometer and the gearbox.
- Shorten the inner cable to a projection of 13 mm (Figure 5).
- Connect the union nut and hose sleeve (Figure 6) and push onto the hose ends (Figure 7).
- Connect friction washer to dog (Figure 8).

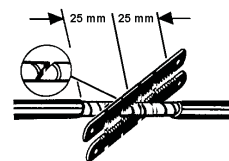

Figure 3

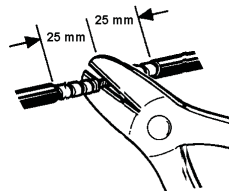

Figure 4

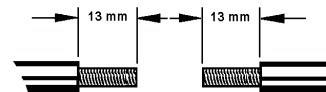

Figure 5



Figure 6

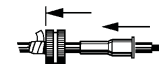

Figure 7



Figure 8

- Remove grease from flex cable and connect dog to flex cable. Using a suitable installation tool, press the dog onto the flex cable (Figure 9).

☞ When pressing in, ensure that the dog is securely positioned and that it runs smoothly.

- Pull the hose sleeve and nut as far as possible in the direction of the dog, to achieve approx. 1-2 mm play (Figure 10). Slightly squeeze the hose sleeve with pliers. Wrap with isolating tape to secure (Figure 11).

- Screw the connecting piece and the speed sensor into the cable (Figure 12).

- Connect speed sensor using the extension cable from VDO (part number: 2152.90 30 0100).

Wire connections for the speed sensor

- Brown - earth (terminal 31)
- Black - power supply (terminal 15), 9 - 16V, 30 mA
- Blue/red - signal for socket A pin 1



Figure 9

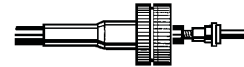
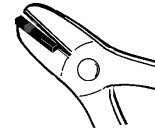

Figure 10

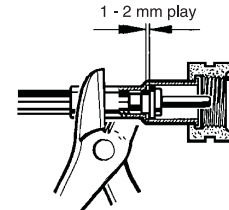

Figure 11

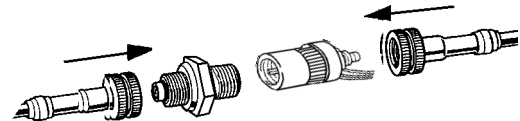



Figure 12

Installation/Connection Manual

7. Installing and commissioning KD-NX1R

- This navigation system has an integrated universal bracket for DIN installation slots. An installation frame is not required. The unit is inserted into the installation slot and secured with the slides supplied. Further information is given in the instructions manual in the chapter, “Removal/installation instructions”.

 **The installation angle of the unit must not exceed -10° to 35° (vertical).**

- Connect the battery.

8. Using GPS for the first time, and sensors

- Switch on the vehicle ignition to start using GPS for the first time and for the sensor test. Switch on KD-NX1R. Enter code (see the Instructions manual for a detailed description).

- Press the **1** multifunction button and the **10** multifunction button simultaneously.

- This calls up the menu for the initial GPS start-up and for the sensor test.

- Move the vehicle several metres forwards or backwards for the speed signal function test.

 The number under **Speed** must change (even at a low speed).
The number under **Speed** should not increase when idling or pressing the accelerator when the vehicle is parked.



SWR4 KA 101.6  GPS WAIT
F: 1 S: 1
Ant.Rdt.ResRer S Sur -> ALM: 2

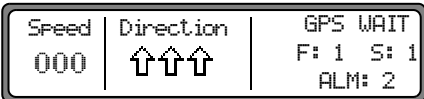

Speed	Direction	GPS WAIT
000	↑↑↑	F: 1 S: 1
		ALM: 2

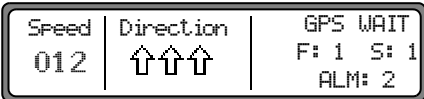

Speed	Direction	GPS WAIT
012	↑↑↑	F: 1 S: 1
		ALM: 2

- Engage the reverse gear for the reverse signal function test.
 -  The arrows under **Direction** must change direction on engaging the reverse gear.



- When using the GPS for the first time, the vehicle must be parked outdoors, while ensuring that it has a clear view in all directions (not in the immediate vicinity of buildings). Information on the GPS reception is given in the right-hand part of the display.

Four different messages may appear:

-GPS OK: GPS reception is already available.



-GPS WAIT: It is necessary to wait for GPS reception. You must wait until GPS OK is displayed.

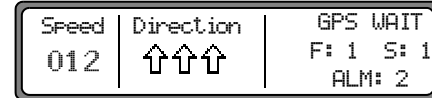

-GPS ANTENNA ERROR: The GPS antenna is not properly connected.



-GPS MODUL ERROR: If this message is displayed, please contact the hotline.



-  You must wait until GPS OK, F: 2 (or F: 3) and ALM: 22 (or a higher value) is displayed.

This procedure (first reception of the necessary GPS data) may take a few minutes. The unit must remain switched on for the entire duration of this procedure. The vehicle must not be moved. If after 5 minutes there has been no change in the values, the parked position (clear view in all directions as far as possible) or the installation location of the GPS antenna must be checked.

Installation/Connection Manual

- The menu for initial GPS start-up and for the sensor test is quit by simultaneously pressing the **1** multifunction button and the **10** multifunction button.



9. Installation of the Navigation Software

- Press the **NAV** button.
- Insert the Navigation CD to install the software for the navigation system.
- After the navigation software has been installed, the adjacent display appears. The language selection is then requested.
- Select the language using the right rotary control **●**. The language selection is accepted by pressing the control.

You can choose either a male or a female voice for some languages.

Select the voice using the right rotary control **●**. The voice is accepted and installed by pressing the control.

The adjacent display appears after installation. Then press the right rotary control **●** to confirm.

-  The language selection can be changed at a later time, as described in the Instructions manual.

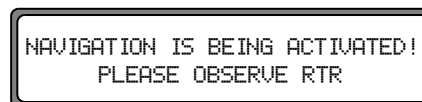

10. Calibration

After commissioning, a calibration journey is required. During the journey, the speed signal (GAL) is automatically adapted to the vehicle-specific data and the gyro sensor is automatically adapted to the installation position of the unit.

The distance to be covered depends on the type of vehicle and the local conditions.

- ☞ The navigation system is only ready for operation on completion of the calibration journey. The main navigation menu is displayed. Final precision is only achieved after a further journey.
- The adjacent display appears after the language installation.

It is possible that GPS reception has deteriorated as a result of changing the vehicle position and due to obstructions. In this case, the adjacent display appears.

- ☞ Adequate GPS reception must be ensured for the calibration ride. This means at least 2-D FIX. With GPS FIX 3-D the calibration will be quicker. However: a lower accuracy of the GPS signal (2-D FIX) does not lead to a poorer calibration, but instead will mean that the time and distance needed for the calibration will increase.

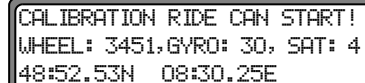

CALIBRATION RIDE CAN START!
WHEEL: 3451, GYRO: 30, SAT: 4
48°52.53N 08°30.25E

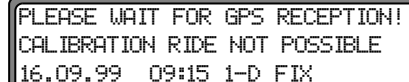

PLEASE WAIT FOR GPS RECEPTION!
CALIBRATION RIDE NOT POSSIBLE
16.09.99 09:15 1-D FIX

Installation/Connection Manual

If, even after a relatively long period of time, the display with the request CALIBRATION RIDE CAN START does not appear, then you should check the GPS reception conditions again (as under Service Mode in the Section “Function test of GPS antenna (GPS INFO)” on page 40).

As soon as the display with the request CALIBRATION RIDE CAN START appears, the calibration ride can be started.

 A calibration ride can also be performed in a non-digitised area. The insertion of the Navigation CD is not absolutely necessary after the navigation software has been installed. Without the Navigation CD inserted, no location is displayed.

- The basic requirement for a calibration ride is: **driving 200 - 300 metres in a straight line, then turning by at least 60 degrees and then driving 200 - 300 metres in a straight line again, and turning again.**

 The direction you turn is of no significance. If these conditions cannot be fulfilled due to the road or the fact that you do not always have optimum GPS reception, this will not lead to a poorer calibration, but will simply mean the time and distance necessary for the calibration ride will be longer.

☞ If the unit is switched off during the calibration ride, language installation is requested when the unit is switched on again. Reinstallation can be skipped by pressing the **NAV** button.

- Calibration has been completed successfully if the main navigation menu is displayed.
- For correct navigation on routes with time-dependent traffic guidance, the time should be set correctly as described under “System settings” in the Instructions manual.



11. Service Mode

In Service Mode, various functions can be checked in detail and the calibration can be modified.

- Switch on the unit (see Instructions manual).
Enter code (see Instructions manual).
- If the unit has already been calibrated, select the main navigation menu by pressing the **NAV** button.
If the unit has not been calibrated, proceed as described in the next point but one.
- Press the **NAV** button again to access the system settings.
- Press and hold the **3** multifunction button. Then press the **5** multifunction button. This calls up the Service Mode.



Installation/Connection Manual

The following functions can be selected in the Service Mode:

- GPS INFO - GPS function test
- CALIBRATION - function for deleting the calibration or for setting a calibration
- CALIBRATION RIDE - display for calibration ride
- MODULE TEST - internal component test
- SENSORS - sensor function test
- SPEECH TEST - voice test
- DEMO - demo mode selection
- VERSION - the status of the Navigation CD is displayed

By turning the right rotary control ●, select the desired entry (large letters) and press to confirm.

Function test of GPS antenna (GPS INFO)

In Service Mode, select GPS INFO with the right rotary control ● and press to confirm.

If functioning properly and with GPS reception, the number of satellites received (e.g. 5), the date and time (e.g. 13.03.99 14:56:08) and the type of positioning currently possible FIX: (e.g. 3D) are displayed.

☞ At least FIX 2D is required for quick and successful calibration. A certain amount of time may be required to reach this value (do not move the vehicle during this period).

In order to quit the GPS test, press the **NAV** button. The unit switches back to the Service Mode.

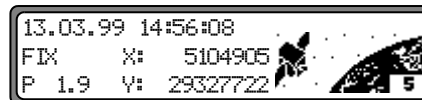

Changing the calibration (CALIBRATION)

Deleting the calibration:

If the navigation system is removed from one vehicle and installed in another, it must be calibrated. However, to do so, the current calibration data must be deleted.

In the Service Mode, select CALIBRATION using the right rotary control  and press to confirm.



Using the right rotary control  select DELETE and press to confirm. The calibration is deleted and the unit returns to the Service Mode.

Calibration setting:

 **Calibration settings should only be made when the values to be entered are known. The unit cannot perform correct route calculations if incorrect values are entered.**

It is possible to provide calibration settings.

In the Service Mode, select CALIBRATION using the right rotary control  and press to confirm.

Using the right rotary control  select MODIFY and press to confirm. Unit rotation can be selected in degrees by turning the right rotary control  and pressing to confirm.

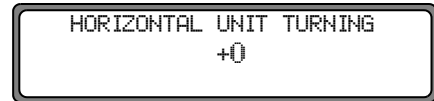

Installation/Connection Manual

- ☞ Unit rotation corresponds to horizontal rotation. A positive value means rotation of the front of the unit towards the driver (LHD).

The unit inclination can now be selected in degrees by turning the right rotary control ● and pressing to confirm.

- ☞ Unit inclination corresponds to vertical inclination. A positive value means upward inclination of the front of the unit.

The number of wheel impulses per wheel revolution (if known) can then be selected by turning the right rotary control ● and pressing to confirm.

- ☞ If the number of wheel impulses per wheel revolution is not known, UNKNOWN must be selected. It is then not possible to enter tyre data.

The previously entered data is displayed once more. If the data entered is correct, press the right rotary control ●. If correction is necessary, select MODIFY by turning the right rotary control ● and press to confirm. The values can then be re-entered.

Once the previously entered data has been confirmed, the tyre data can be entered or self-calibration can be started. To enter the tyre data, select INPUT TYRE VALUES by turning the right rotary control ● and press to confirm.

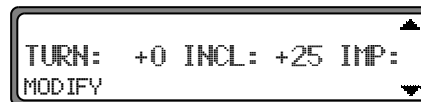

Enter the correct tyre size using the right rotary control and confirm the entry by pressing for more than 2 seconds.

- ☞ The letter “R” cannot be entered. 3 numbers must be entered before and after the slashes. Insert a “0” for any missing numbers.

Example:

Specification in vehicle registration papers: 185/55R15
81T

Input into unit: 185/055/015

Then select between **NEW TYRE TREAD** and **USED TYRE TREAD** by turning the right rotary control ● to enter the approximate tread depth value.

Press the right rotary control ● to confirm the selection.

The previously entered data is displayed once more. If the data entered is correct, press the right rotary control ●.

If correction is necessary, select **MODIFY** by turning the right rotary control ● and press to confirm. The values can then be re-entered.

After confirming the tyre data or the previously confirmed point **START SELF CALIBRATION**, the adjacent display appears.

After a short time, the unit switches to the main navigation menu or the calibration ride is requested.

- ☞ The unit is now in calibration status 2. Absolute precision is, however, only achieved as of calibration status 3.

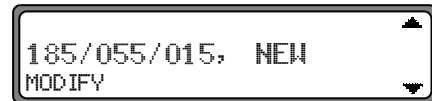

Installation/Connection Manual

Status of calibration ride (CALIBRATION RIDE)

In the Service Mode, select CALIBRATION RIDE using the right rotary control  and press to confirm.

The calibration status (e.g. STATUS: 2) and the type of positioning (e.g. 3D) are displayed. After completing calibration, the street in which you are currently driving is displayed (provided that it is digitised) instead of WHEEL and REV..

Testing the system components (MODULE TEST)

A test program automatically tests the internal components of the navigation system.

In the Service Mode, select MODULE TEST using the right rotary control  and press to confirm.

If MODULE TEST OK is displayed, press the  button. The unit switches back to the Service Mode.

Function test of the GAL signal, reverse signal, internal sensors (SENSORS)

- In the Service Mode, select SENSORS using the right rotary control  and press to confirm.
- Move the vehicle several metres forwards or backwards for the GAL signal function test.

-  The number after WHEEL# should increase (even at a low speed).
The number after WHEEL# should not increase if idling or pressing the accelerator when the vehicle is parked.

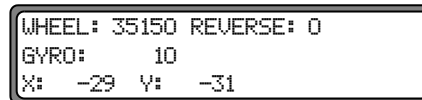

- Engage the reverse gear for the reverse signal function test.
 - ☞ The number after REVERSE# should jump from 0 to 1 (1 to 0).
- Drive round a bend to test the function of the internal sensors.
 - ☞ The values after X# and Y# should change.

In order to quit the sensor test, press the **NAV** button. The unit switches back to the Service Mode.

Testing the voice (SPEECH TEST)

A test program is used to test the voice.





- In the Service Mode, select SPEECH TEST using the right rotary control **●** and press to confirm. The announcement “Please insert Navigation CD” is given. By pressing the right rotary control **●**, the announcement can be repeated. After completing the test, press the **NAV** button. The unit switches back to the Service Mode.



Installation/Connection Manual

Demo Mode (DEMO MODE)

The demo mode is intended for demonstration purposes. A fixed location is given to the unit (Hamburg Werderstraße).

- In the Service Mode, select DEMO MODE using the right rotary control  and press to confirm. Select between ON and OFF by briefly pressing the right rotary control . By holding down the right rotary control , the selection is confirmed.
- You can now enter a destination as described in the Instructions manual.
- To switch off the demo mode, select OFF with the right rotary control  and press to confirm.

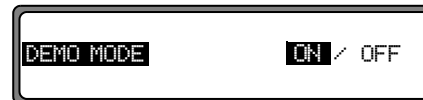
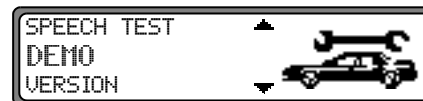

12. Connections

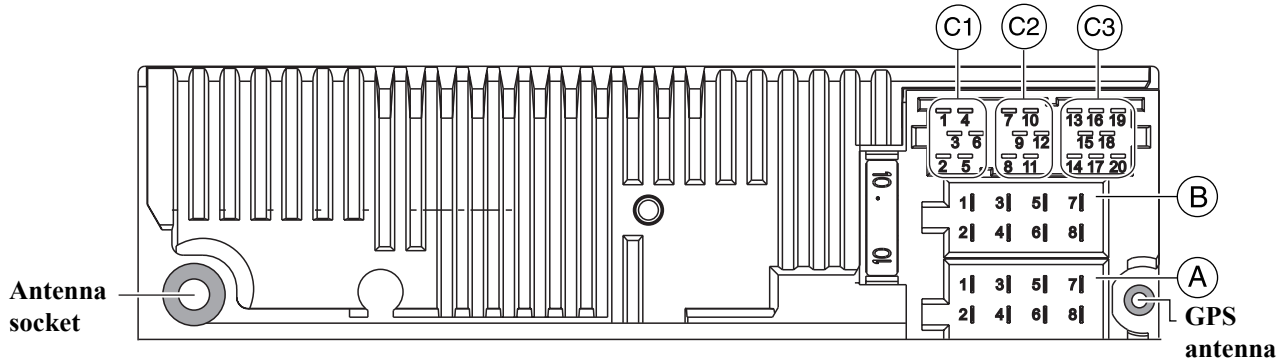

Socket A

- 1 Speed signal (GAL)
- 2 Reversing lamp signal
- 3 Telephone mute/clearing function
- 4 Permanent positive (terminal 30)
- 5 Control output for automatic antenna/amplifier
- 6 Illumination (terminal 58)
- 7 Switched positive (terminal 15)
- 8 Earth (terminal 31)

Socket B

- 1 Loudspeaker rear right +
- 2 Loudspeaker rear right -
- 3 Loudspeaker front right +
- 4 Loudspeaker front right -
- 5 Loudspeaker front left +
- 6 Loudspeaker front left -
- 7 Loudspeaker rear left +
- 8 Loudspeaker rear left -

Socket C1

- 1 LineOut rear left
- 2 LineOut rear right
- 3 AF earth
- 4 LineOut front left
- 5 LineOut front right
- 6 Subwoofer LineOut

Socket C2

- 7-12 Special connection for JVC CD changer

Socket C3

- 13 AF telephone input
- 14 Earth - telephone input
- 15-17 Special connection for JVC CD changer
- 18 CD AF earth (AUX)
- 19 CD AF left (AUX)
- 20 CD AF right (AUX)



JVC
VICTOR COMPANY OF JAPAN, LIMITED